

Autotrol® Magnum Cv™ Switch Kits

Mounting and Breakaway Kit Instructions

Optional switch kits can be used on the Magnum Cv control valve to provide electrical signaling capabilities. Used in conjunction with breakaway cams, the switches will provide a signal to external devices during the various cycles of the control valves' operation.

Switch Mounting Instructions

For Single Tank Control Valves

1. Fasten the switch-mounting bracket to the Magnum Cv control valve using the thread-forming mounting screw (see Figure 1). The shorter, clipped edge of the bracket should be positioned over the guide pin and screw hole located behind the B1/B2 cam.

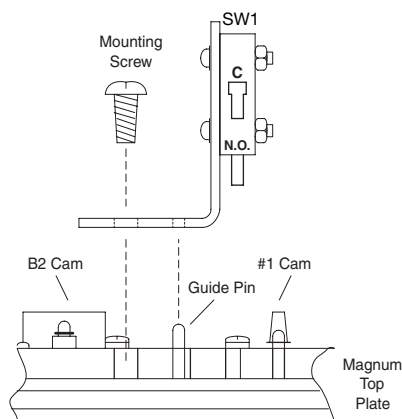

Figure 1

2. Attach the switches to the bracket using the machine screws, nuts and washers provided. The screws should be inserted so that the washer and nuts are on the backside of the switch SW1. When mounting a single switch, the switch is mounted to the back of the bracket directly in front of the number one cam (see Figure 1). When a triple switch is mounted, one switch is located on the back of the bracket and two are located on the front (see Figure 2). For multiple switches it is easiest to slide two switches onto the screws and then insert the screws through the bracket. The final switch is then added to the screws and fastened with the washers and nuts (see Figure 2). Switches are mounted with the switch arm adjacent to the breakaway cams and the electrical contacts directed away from the camshaft (see Figure 3).
3. Each switch has three terminals (Figure 4), the common terminal is on the side (labeled COM1), and two terminals are on the bottom. The lower terminal which is closest to the camshaft is the normally closed contact (labeled NC2), with the remaining terminal the normally open contact (labeled NO3). Connect the cable lead wires to the appropriate terminal using the crimp-on terminal connectors provided. Auxiliary switch cables are available in 10-foot (P/N 1041065) and 20-foot (P/N 1041066) lengths. The connections for these cables are: black to common terminal, red to normally open terminal and green to normally closed terminal.

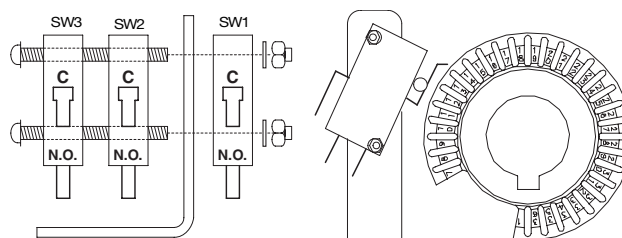

Figure 2

Switch cam assembly as viewed from back.

Figure 3

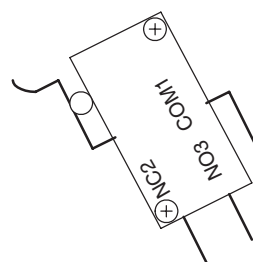

Figure 4

Breakaway Switch Cam P/N 1034356

Breakaway Cam Application

The breakaway switch cam has been designed to further increase the versatility of the Magnum Cv Series control valve. The complex water treatment systems that are required today, to treat an ever-challenging water supply and to meet stricter clean water standards, typically include external devices that need to be integrated into the total water treatment process. Toward the goal of facilitating these requirements, the Magnum Cv Series control valve, with the multi-switch option and breakaway switch cams, can provide two or three electrical outputs (depending upon the system configuration) during the service and/or regeneration cycle.

Breakaway Cam Design

The breakaway switch cam has been divided into 36 equal sections with each section representing approximately 10-degrees of cam rotation. Each section is consecutively numbered 1 through 36 to aid in customized cam operating design. Each cam section, as well as the outside ring of the cam that the switch arm rides on, is molded of a high strength, co-polymer resin. Although a single cam section is strong enough to operate the switch, it is recommended that a minimum of three continuous cam sections always be incorporated into the cam timing design for the on/off operation of the switch. Likewise, it is recommended that a minimum of three cam sections be removed to ensure the proper on/off operation of the switch. The breakaway switch cam (P/N 1034356) **CANNOT** be used as a substitute for any standard Magnum Cv Series **pilot cam lobe**.

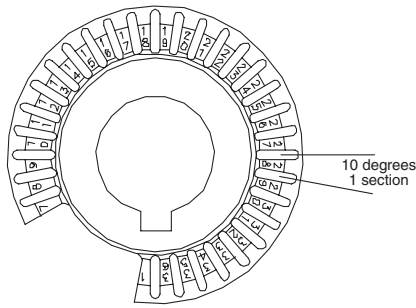

Figure 5

Breakaway Switch Cam Instructions

Based on the system requirements and the external devices used, determine the program timing, ie., when the external devices need to operate, either open or close. Typical external devices would be solenoids, solenoid operated diaphragm valves, relays, and chemical feed pumps. Using the instructions below, sections can be removed from the breakaway cam to allow signaling during the desired cycles. One cam can be used to signal multiple noncontiguous cycles.

1. Determine which breakaway cam sections need to be removed using the chart below. In order to assure that switch deactivation occurs, at least three sections must be removed from the breakaway switch cam. (**Please Note:** The sections should be removed in a **clockwise** fashion, starting with the first number and ending with the second, see Figure 6). Utilizing the timing chart on the back, determine if the switch arm should be riding on the cam [actuated] or not [relaxed].
NOTE: Remember that the switch operates either Normally Open or Normally Closed depending upon how it is wired.

Cycle	Section Numbers
Service	19, 20, 21, 22, 23, 24, 25
Backwash	26, 27, 28, 29, 30, 31, 32
Brine	33, 34, 35, 36, 1
Slow Rinse	2, 3, 4, 5, 6, 7, 8, 9, 10
Fast Rinse	11, 12, 13, 14
Refill	15, 16, 17, 18

EXAMPLE:

Removing sections 36 through 13 in a clockwise direction will provide an electrical signal during the Slow Rinse cycle.

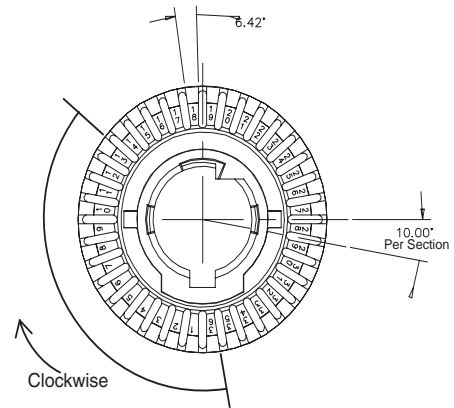

Figure 6

2. Using diagonal cutters or a razor knife, cut through the cam on either side of the section you wish to remove. (The breakaway cam section should be trimmed to the edge of the section which is to REMAIN on the breakaway cam, see Figure 7.) Cut the outside ring first, then at the score line on the bottom of each section near the center ring. **Helpful Hint:** When starting to remove sections, start two or three sections **before** the section required. Then remove one section at a time until the required section is reached. This procedure eliminates the potential of damage to usable sections.

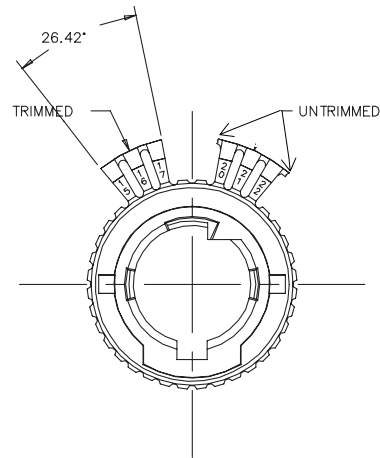

Figure 7

3. When all of the desired sections have been removed, add the breakaway switch cam(s) to the camshaft after the B1/B2 pilot cam. The switch cam can be installed onto the camshaft in only one direction. The numbers on the breakaway switch cam should face the controller.
4. Replace the standard pilot cams in the proper order and reinstall the camshaft onto the control valve. Refer to the Magnum Cv Series Installation and Service Manual for instructions on the removal and replacement of the camshaft assembly.