



# **UVR SERIES**

## **ULTRAVIOLET WATER TREATMENT SYSTEM**



UVR04 MODELS: 4 GPM, 1/2 INCH MNPT, 120V/60HZ

UVR07 MODELS: 7 GPM, 3/4 INCH MNPT, 120V/60HZ

UVR07U MODELS: 7 GPM, 3/4 INCH MNPT, 100-240V/50-60HZ

UVR10 MODELS: 10 GPM, 3/4 INCH MNPT, 100-240V/50-60HZ

UVR15 MODELS: 15 GPM, 1 INCH MNPT, 100-120V/50-60HZ



## TABLE OF CONTENTS

What's In The Box (Component List) . . . . .	4
Safety Instructions . . . . .	5
1) Information . . . . .	5
2) About Ultraviolet (UV) Disinfection . . . . .	5
3) Disinfection Chamber . . . . .	6
4) Important Safety Precautions . . . . .	6
5) Preparation For Installing UV System . . . . .	8
a) System Inspection . . . . .	8
b) Water Quality . . . . .	8
c) Water Supply Pressure Check . . . . .	8
d) Location Selection . . . . .	8
6) Installation Instructions . . . . .	10
a) Quartz Sleeve Installation . . . . .	11
b) UV Lamp Installation . . . . .	12
c) Plumbing System Sanitization Procedure . . . . .	12
d) Countdown Timer and Timer Holder (-T and -M Models) . . . . .	13
7) Operation and Monitoring . . . . .	14
8) UV Monitor (Option) . . . . .	14
a) General Monitor Operation . . . . .	14
b) Monitor Installation . . . . .	14
c) Monitor Calibration . . . . .	15
d) Wiring for 230V . . . . .	16
9) Maintenance . . . . .	17
a) UV Lamp Maintenance . . . . .	17
b) Quartz Sleeve Cleaning Procedure . . . . .	17
c) Lamp Recycling . . . . .	18
d) Countdown Timer (Option) . . . . .	18
UVR Series Replacement Parts . . . . .	19
Technical Specifications . . . . .	20
Troubleshooting . . . . .	21
Maintenance Log . . . . .	Back Cover

## WHAT'S IN THE BOX

Before installing your UV unit, take a moment to make sure you are familiar with all of the parts included in the box.



1. UV Chamber - Qty (1)
2. Chamber Mounting Clips - Qty (2)
3. Compression Nuts - Qty (2)
4. UV Lamp - Qty (1)
5. Quartz Sleeve - Qty (1)
6. O-Rings - Qty (2)
7. Ballast - Qty (1)
8. Ballast Mounting Bracket - Qty (1)
9. Sight Glass - Qty (1)
10. Timer and Timer Holder (Optional) - Qty (1)
11. UV Monitor and Sensor (Optional) - Qty (1)

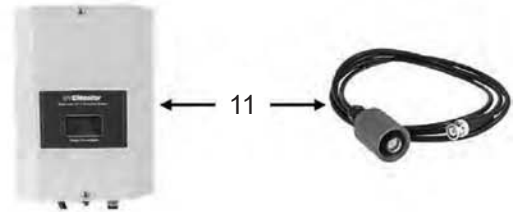

### UVR Series Features

- Effective microbiological protection
- Stainless steel disinfection chamber
- High efficiency electronic ballast power supply
- Lamp operation indicator
- Audible alarm upon lamp failure
- Sight glass
- Horizontal or vertical mounting

## **SAFETY INSTRUCTIONS**

In order to protect end users and operators from injury, safety precautions must be followed. This Installation, Operation and Maintenance (IOM) Manual outlines important safety issues.

### **1) INFORMATION**

Please read this manual prior to installing, starting up, and operating the equipment. The equipment uses the latest in UV technology, and has been designed to make operation and maintenance easy.

The quality of the liquid entering the UV system needs to be monitored. Based on water quality, the UV system will need to be cleaned on a periodic basis. Maintenance of the UV system will require replacement parts. It is suggested that key spare and replacement parts be kept on hand. For best operation, always use manufacturer recommended replacement parts. Other replacement parts could result in damage to the system and void the warranty.

### **2) ABOUT ULTRAVIOLET (UV) DISINFECTION**

The technology uses UV light to target and disable disease-causing microorganisms and pathogens.

Over 100 years ago, scientists discovered that if you exposed pathogens to UV light, their reproduction was limited. The UV light source they used resided in the UVC range of the light spectrum. Specifically, they discovered that light in the 254 nanometer (NM) range was the most effective wavelength for this process.

When many pathogens are exposed to UV light, their cells become damaged and this damage inhibits reproduction. The UV light, produced by a special UV lamp, damages the cells' DNA and RNA and once damaged, they are unable to replicate. This physical process renders them harmless. The amount of damage is a result of the intensity of the UVC output multiplied by the time the pathogens are exposed to the light. The applied dosage is commonly referred to as microwatts or millijoules and is often expressed as  $\mu\text{Ws}/\text{cm}^2$  or  $\text{mJ}/\text{cm}^2$ . Most residential applications require a UV dosage ranging from 16,000 up to 40,000  $\mu\text{Ws}/\text{cm}^2$  depending on the water quality.

Why are more consumers selecting UV technology?

- a) UV is considered a green technology
- b) No chemicals are added, so there is no need for chemical removal
- c) No chemical storage
- d) UV works instantly without requiring a residence time
- e) Easy maintenance

### 3) DISINFECTION CHAMBER

The chamber is manufactured from 304 stainless steel. For Standard and Timer (-T) models, the chamber has an inlet and outlet connection. For Monitor (-M) models, the chamber has an inlet and outlet connection and a sensor port.



**Chamber for Standard and Timer (-T) models**



**Chamber for Monitor (-M) models**

### 4) IMPORTANT SAFETY PRECAUTIONS

Read and follow all safety precautions to guard against injury. Basic safety precautions must be observed. Keep on hand for future reference.

**UV lamps and their quartz sleeves can become razor sharp if broken. Take care when installing and removing quartz sleeves. Only hand-tighten compression fittings. Do not use wrenches or other tools.**

#### **CAUTIONS:**

- Ultraviolet light (UVC) is harmful to the eyes and skin. Only use UV lamps inside the disinfection chamber with the appropriate protective covering. Avoid exposure to UVC radiation.
- Only use the UVR system for its intended purposes as described in the IOM Manual. The use of attachments not recommended or sold by the manufacturer may cause an unsafe condition.
- The UVR system must be properly installed in accordance with the IOM Manual and in compliance with all applicable local and state regulations before use. Read and observe all important notices on the UVR system.
- The UVR system is intended for indoor use only.

## **ELECTRIC SHOCK WARNINGS:**

- To avoid possible electric shock, take special care when using water with this equipment. Always shut off and disconnect power to the unit before:
  1. Making repairs—It is strongly recommended that a qualified individual who fully understands the IOM Manual perform service and/or repairs to the UVR system.
  2. Cleaning
  3. Replacing a UV lamp
- Do not operate the UVR system if it has a damaged cord or plug, if it is malfunctioning, or if it is dropped or damaged in any way.
- The power cord of the UVR system is equipped with a 3-prong grounding plug that mates with a standard 3-prong grounded wall outlet to minimize the possibility of electric shock. Be sure the outlet for the UVR system is wired and grounded properly. **DO NOT** under any circumstances cut or remove the third prong from the power cord.
- Always unplug the UVR system from the outlet when not in use, before putting on or taking off parts, and before cleaning. Never unplug by pulling on the power cord. Always grip the plug firmly and pull straight out of the outlet.
- Shut down the UVR system before servicing:
  1. Turn off the water supply to the UVR system.
  2. Disconnect all power to the UVR system.
  3. Drain the water from the system.

## **EYE PROTECTION:**

- **EYE PROTECTION MUST BE WORN!** Ultraviolet light is extremely harmful to the eyes and skin and will cause burns. Do not look directly or indirectly at the UV light.
- Never operate the UV lamp outside of the UV system.
- Do not expose your skin for any prolonged time. Use protective clothing and eyewear (make sure it is UV resistant) when servicing the equipment.
- If accidentally exposed to UV light for an extended period, immediately seek medical attention. Symptoms for eye exposure include burning, itching, and redness. Symptoms for skin exposure are similar to sun burn.

## **HAND PROTECTION:**

- Use cotton gloves when handling the lamps and quartz sleeves. Skin oils will adhere to the lamps and sleeves and prevent UV light from properly emanating.
- If the sleeves become dirty, wipe them with a clean, lint-free cloth and denatured alcohol.

## 5) PREPARATION FOR INSTALLING UV SYSTEM

Before you begin, perform the following pre-installation steps:

### a) System Inspection

Ensure that the UVR system is correctly sized for the desired dosage and flow capacity. (See Table 3 in “Technical Specifications” section of IOM Manual.)

### b) Water Quality

For optimum performance of the UVR system, water quality is extremely important. Proper pretreatment is essential for the UVR system to operate as intended.

UV disinfection dosages are dependent upon the quality and clarity of the incoming water. Impurities in the water can interfere with the UV intensity and cause the dosage to fall to unsafe levels. Have the water tested to determine that it meets the standards in Table 1. If any of the elements exceed the maximum levels shown in Table 1, contact your water professional for recommendations for proper pretreatment. All UVR systems are rated for a UV Transmission (UVT) rate of 95% or greater. If your UVT is less than 95%, contact your water professional.

The following Table 1 shows levels that are recommended for installation:

**Table 1 — Recommended Water Standards for Installation**

Element	Recommended Maximum Levels (1mg/L=1ppm)	Actual Value
Turbidity	<5 NTU	
Suspended Solids	<5 mg/l	
Color	None	
Iron	0.3 mg/l	
Manganese	0.05 mg/l	
pH	6.5 to 9.5	
Hardness	<120 ppm	

### c) Water Supply Pressure Check

Check the pressure of the water supply. The UVR system is designed for a maximum water pressure of 100 psi. If your water pressure exceeds 100 psi, install a pressure reduction valve before installing the UVR system.

### d) Location Selection

Select a location that meets the following guidelines:

- The unit must be installed between the cold water source and the water heater as inlet temperature must not exceed 100°F. (See Figure 1 in “Installation Instructions” section of IOM Manual for proper installation sequence.)
- The disinfection unit can be installed either horizontally or vertically. (See Figure 1 in “Installation Instructions” section of IOM Manual for water flow direction.)



- The unit must be within 5 ft of an electrical outlet. A 6 ft cord is included with the system.
- The power supply contains sensitive electronic components. It is recommended that the unit be plugged into a surge suppressor to help protect the electronic components.
- The unit must be protected from freezing. Freezing damage will void the warranty.
- The unit should be placed where a potential leak will not cause water damage. The manufacturer is not responsible for water damage.
- Vibration of ultraviolet equipment will damage lamps and lead to premature system failure. Choose a location for the UVR system that is isolated from vibration. Potential vibration sources include heavy equipment, poorly connected pipes, and erratic or improper pumps. A water hammer may cause o-ring failure. If the system is subject to water hammer conditions, it is recommended that a water surge suppressor be installed.
- There must be enough clearance to remove the UV lamp and the quartz sleeve for replacement and regular maintenance.
- Recommended clearance is the length of the unit plus four inches. (Refer to "Installation Instructions" and "Technical Specifications" sections of IOM Manual for additional clearance information.)

## 6) INSTALLATION INSTRUCTIONS

**NOTE:** Your UVR Series UV System can be mounted either horizontally or vertically.

**WATCH FOR CLEARANCE!** Be sure to allow a minimum clearance from one end of the unit equal to the length of the unit plus 4 inches. Example: The UVR10 model is 29 inches in length, thereby requiring a minimum 33 inch clearance to the side of the mounted unit. This distance is necessary in order to allow sufficient room for replacement of the lamp and quartz sleeve.

**ELECTRICAL SHOCK!** Check for hidden electrical wiring before drilling holes.

**INSTALLATION ORIENTATION!** Water flow must be from the bottom to the top of the unit for a vertical installation. Inlet and outlet must be pointing upward for horizontal installation.

**POWER SUPPLY MOUNTING!** The power supply should be mounted to the wall, near the disinfection chamber. It is recommended to place the power supply above the chamber and away from any water connection point(s). This will help avoid water from potentially releasing onto the power supply from a leak at a connection point or a "sweating" system. To further minimize the possibility of any water entering the power supply, make sure to allow for a "drip-loop" on the lamp/power cord.

**Figure 1 — Typical Correct Installation**

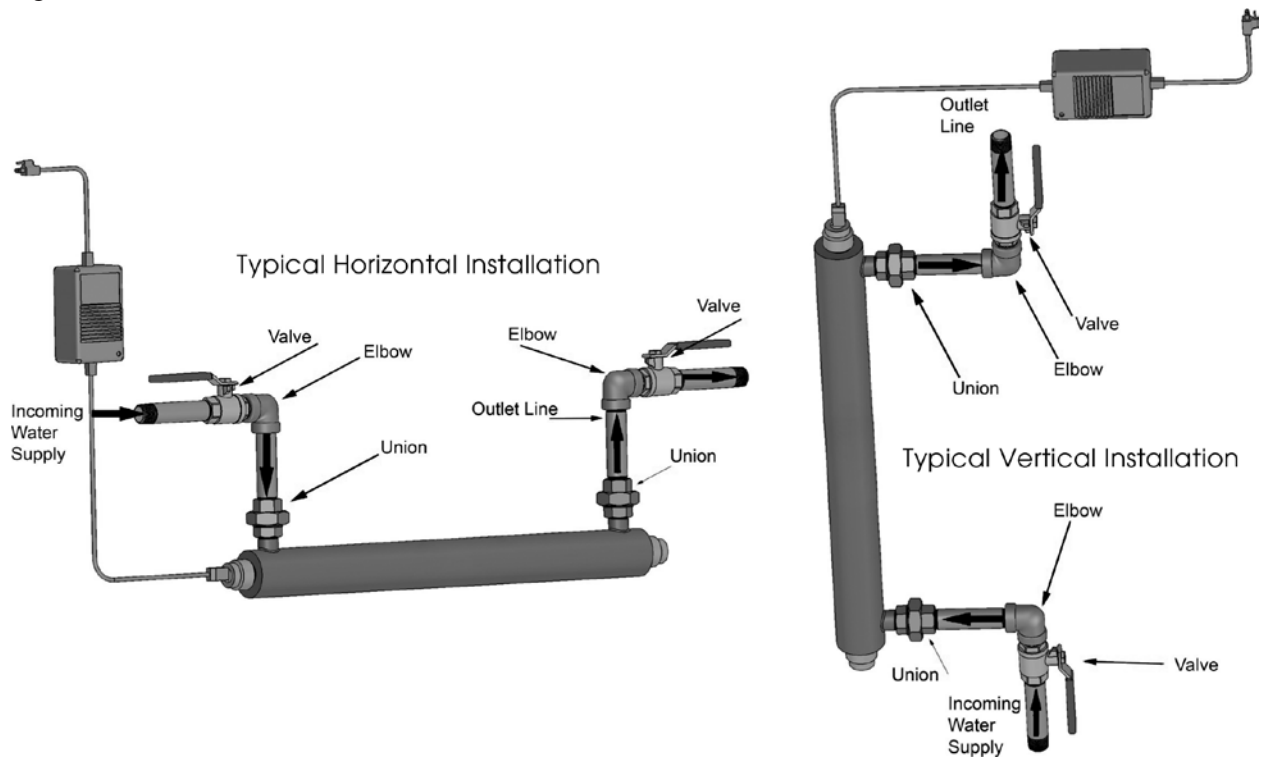

### a) Quartz Sleeve Installation

The quartz sleeve surrounds the lamp and prevents water from contacting the lamp and electrical parts. The sleeve is made of pure fused quartz which allows 99% of the ultraviolet light to pass through.

The quartz must be kept clean and free of organic buildup to ensure optimum ultraviolet transmission. The quartz sleeves need periodic cleaning with the frequency of such cleanings determined by the quality of the water passing through the system. **Use cloth gloves to handle quartz sleeves and UV lamps to avoid putting fingerprints on the sleeves and lamps.**

After the ultraviolet unit has been secured and the inlet/outlet piping connections have been made, remove the compression nuts from each end of the disinfection unit.

Take great care when removing the quartz sleeve from the packing carton.

Slowly and carefully slide the quartz through the chamber until it protrudes equally beyond the nipple on each end of the chamber. Place an o-ring over each end of the quartz and push the o-rings back until they stop at the nipple.



Be very careful when installing the compression nuts over the quartz sleeve. Tighten each compression nut simultaneously by hand, making sure that the sleeve protrudes from each nipple equally. If the sleeve is not centered, it may cause the system to leak. Look inside the compression nuts to make sure that each of the sealing o-rings is properly located. The placement of the sealing o-rings should look identical on both ends. If both ends are not similar, reinstall the sleeve until they are alike.

**ONLY TIGHTEN BY HAND – NEVER USE PLIERS.** Make sure as you tighten the compression nut that you maintain a clearance between the stop ridge machined in the compression nut and the edge of the quartz sleeve.



After you have tightened the compression nuts, verified correct placement of the o-rings, and secured all other plumbing connections, open the outlet valve. Slowly open the inlet valve and

flush out all remaining air. Then, close the outlet valve and open the inlet valve fully. Check the unit for leaks. If you find a leak at a compression nut, tighten the nut further. If the leak continues, drain the unit and inspect the quartz o-rings and quartz sleeve for possible damage. Once you complete checking the unit, carefully reassemble the o-rings and tighten the compression nuts. Re-pressurize the unit and check again for leaks. Do not install the lamp or ballast until all leaks have been corrected.

## b) UV Lamp Installation

The UV lamp is very fragile. Do not handle it with bare hands. **Use clean cotton gloves or cloth when handling lamp to keep it free of dust or fingerprints.** If dust or fingerprints get on the lamp, wipe it with a clean, lint-free cloth and denatured alcohol.

Take care when removing the ultraviolet lamp from the packing carton. First, loosen the “set screw” on the compression nut. This does not have to be completely removed. Slowly and carefully slide the lamp into the quartz sleeve. Attach the ultraviolet lamp to the socket and ensure the socket is pushed all the way down to the base of the lamp for proper contact. Then slide the compression cap onto the compression nut and tighten the set screw.

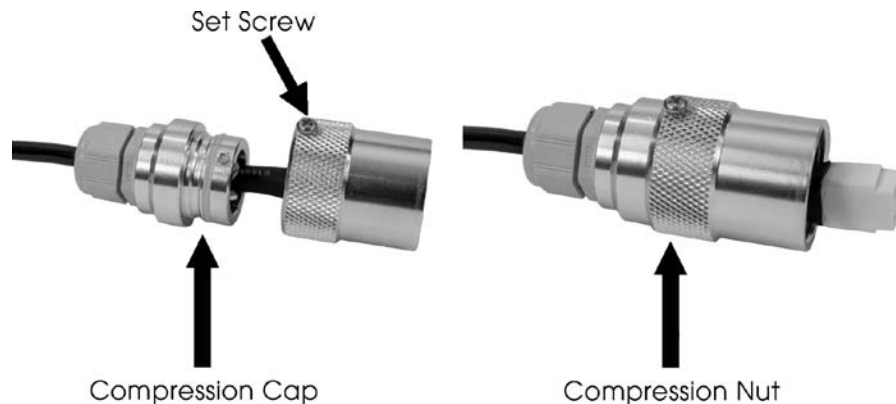

## c) Plumbing System Sanitization Procedure

It is recommended before the initial use of your UVR system and after routine maintenance procedures, to sanitize your water system to ensure that no organisms are present. Water in the well and storage tank should be treated with a strong chlorine solution to destroy disease organisms. All pipelines and fixtures in the distribution system should be rinsed and flushed with chlorinated water.

Ordinary household liquid laundry bleach (about 5.25% available chlorine) can be used to sanitize the plumbing system. The quantity required depends on the volume of water to be treated. The United States Environment Protection Agency (EPA) indicated that about 100 parts of chlorine, by weight, mixed in a million parts of water will destroy essentially all waterborne disease organisms.

The amount of chlorine depends upon the diameter and depth of your well. As a general rule of thumb, use 1/2 gallon to treat an 8 inch diameter x 80 ft deep well, and one gallon for anything larger. Pour household bleach into your water system. If you have a filter container, fill it with bleach. If you have no filter then introduce chlorine directly into your well. You may contact your State Extension Service or a water treatment specialist for additional information.

Open hot and cold water taps throughout the house and let the water run until you detect a chlorine odor. To ensure that the hot water heater is also purged, allow the hot water to run until the water becomes cold. Turn off the taps and allow the water to stay in the pipeline for about six hours, or overnight, but not more than 36 hours to avoid corrosion.

Open hot and cold water taps throughout the house and let the water run until the chlorine odor disappears.

Flush the UV system for 5 minutes prior to start-up.

**NOTE: Always follow the sanitizing procedures required by applicable state or local laws.**

**d) Countdown Timer and Timer Holder (-T and -M Models)**

-T and -M models come with a countdown timer and timer holder. The countdown timer is used to remind you when to replace the UV lamp. The timer is equipped with an audible alarm that sounds after 365 days has lapsed. The timer also has the ability to count up once the time has expired.

Attach the timer onto the holder by first removing the protective paper covering the adhesive strip on the back of the timer, then pushing the timer down into the holder and snapping it in place. The timer holder needs to be attached to the chamber. To attach the holder, unscrew one side of the metal mounting strap, wrap the strap around the chamber, and then retighten the screw to hold the timer assembly in place. Set the timer by pressing the reset button using the tip of a paper clip or something similar.



## 7) OPERATION AND MONITORING

The UVR system will provide years of safe, effective, and reliable disinfection with minimal routine maintenance. Establish and implement a routine physical monitoring and maintenance schedule. Monitor the ultraviolet lamp display on the ballast. Immediately replace any failed lamp.

The ballast located midway on the power cord has built-in monitoring functions to indicate lamp operation. The LED will glow green when the lamp is operational and red when the lamp has failed. There is also an audible alarm that will sound when the lamp has failed. It is strongly recommended that a surge suppressor be installed between the power cord and the outlet, or the unit to be plugged into a GFI outlet to protect the sensitive electronics in the ballast.

## 8) UV MONITOR (OPTIONAL)

### a) General Monitor Operation

The UV Monitor option consists of a UV sensor probe, a UV monitor board, and a UV digital display.

The sensor probe constantly measures the UV intensity output of the lamp. The sensor probe is connected to the UV chamber at the sensor port in close proximity to the lamp. As the sensor probe monitors the UV output of the lamp, signals are sent from the sensor probe to the monitor board for processing. The results are then displayed as a percentage value from 0–100% on the digital display.

When a new UV lamp is installed, the monitor board must be recalibrated to 100%. As a lamp ages, its ability to generate effective UV light diminishes. Lamp effectiveness is measured from initial startup or Beginning of Life (BOL), until its end of effectiveness or End of Life (EOL). The UV display percentage will indicate the lowering UV intensity throughout the life of the lamp.

The sensor's constant monitoring of the UV intensity on a 0–100% scale allows the system user to identify abnormalities in UV output—such as lamp or quartz sleeve fouling. Thresholds are set to activate an alarm system notifying the system user of a potential problem.

### b) Monitor Installation

1. Determine a suitable location to install the UV monitor. The mounting location should be in close proximity to the ultraviolet treatment chamber. It is recommended to place the monitor above the chamber and away from any water connection point(s). This will help avoid water from potentially releasing onto the power supply from a leak at a connection point or a "sweating" system. To further minimize the possibility of any water entering the power supply, make sure to allow for a "drip-loop" on the lamp and power cord.
2. Before tightening the sensor probe, **UV SYSTEM MUST BE DEPRESSURIZED AND DRAINED OF WATER.** (See "Plumbing System Sanitization Procedure" section in IOM Manual.)

Do not use a wrench to tighten the sensor probe. This can only be done by hand tightening. Ensure the sensor probe is as tight as possible by hand. Overtightening may result in breakage and damage to the sensor probe assembly.

3. Once installed, connect the female BNC connector from the sensor probe to the male BNC connector on the UV monitor.
4. Plug the power cord into the wall outlet with the appropriate required voltage.
5. The audible alarm will sound for approximately three (3) minutes when the UV monitor is turned on. This time delay is designed to allow the ultraviolet lamp to heat up and reach the safe output level.
6. During periods of no flow, the UV lamp will heat up causing the UV intensity to drop below the set point. When water flow resumes, allow the system to run for at least three (3) minutes before checking the UV intensity.

**PROPER EYE PROTECTION SHOULD BE WORN WHEN WORKING WITH WITH UV LAMPS.**

### c) Monitor Calibration

The ultraviolet meter can only be calibrated when the power switch is in the ON position, the lamp is operational, and water is flowing through the system. Prior to any calibration, allow the lamp to warm up for at least three (3) minutes while water is running through the system. During this three minute warm up, the buzzer will sound. Only lamps that have been operational for 100 hours should be calibrated.

To set the low UV intensity alarm:

1. Push and hold down the SET button. (See Figure 2.)
2. The low SET point of the meter should be 85%. If adjustment is needed, turn the SET potentiometer (see Figure 3) clockwise to raise the SET point, or turn counterclockwise to lower the SET point.
3. Release the SET button to return to the Run position.
4. To test for low UV intensity, turn the SCALE potentiometer (see Figure 3) below the SET point level.
5. Adjust SCALE display to 100% to return to the Run position.



**Figure 2**



**Figure 3**

**d) Wiring for 230V**

The meter board of the UV monitor is capable of operating on 115V or 230V. The unit has been supplied with a 115V power cord.

To run at 230V:

1. Locate the internal voltage adjustment switch on the monitor board.
2. Switch to the desired position of 230V.

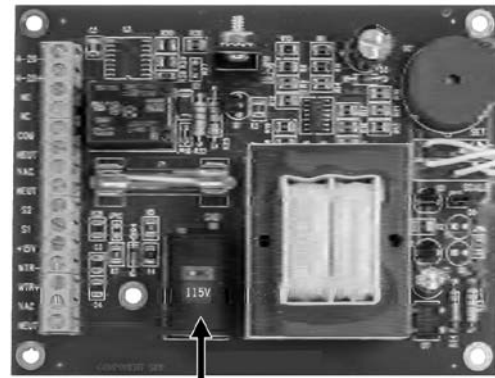

Voltage Adjustment Switch

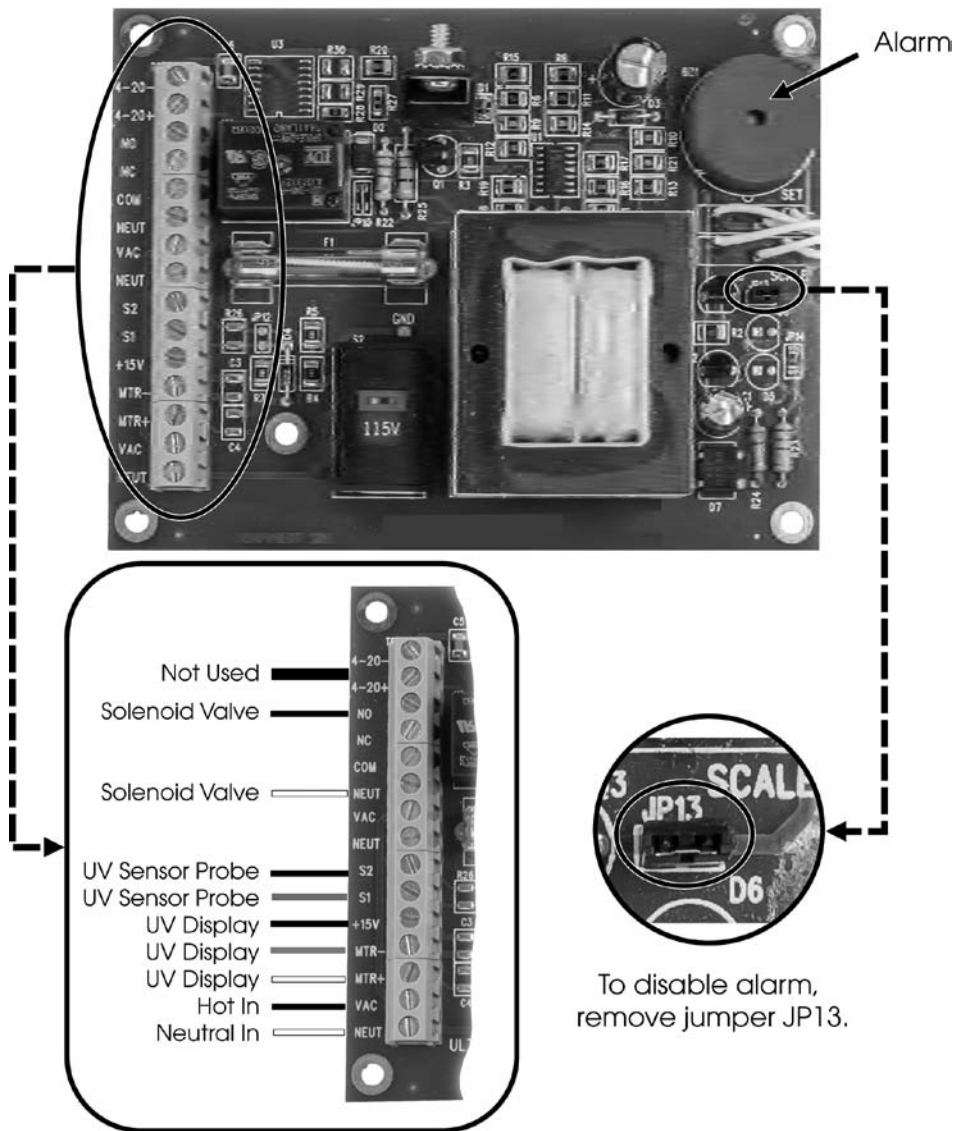
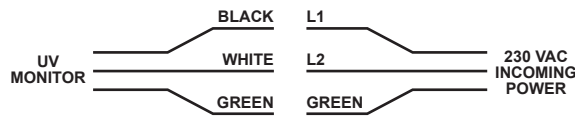



## 9) MAINTENANCE

**It is recommended that all installation and maintenance procedures should be done in accordance with state and local electrical and building codes.**

### a) UV Lamp Maintenance

The UVR system will give many years of safe and effective disinfection service with minimal routine maintenance.

#### **Replace your UV lamp on an annual basis!**

The UV lamp of the UVR system has a rated life of 9,000 hours, which is approximately one year of continuous service. Beyond 9,000 hours, the light seen from the sight glass will continue to glow blue. However, ultraviolet light is not visible to the human eye. The light seen from the sight glass is not in the UVC range of the light spectrum which provides microorganism reduction. The light seen from the sight glass is only an indicator that the UV lamp is lit. It is therefore important that you or your water professional keep accurate records of when lamps are installed, and replace them annually. For your convenience, a maintenance log has been provided in the back of the IOM Manual.

The UV lamp is very fragile. Do not handle it with bare hands. **Use clean cotton gloves or cloth when handling the lamp to keep it free of dust or fingerprints.** If dust or fingerprints get on the lamp, wipe it with a clean cloth and denatured alcohol.

Take care when removing the ultraviolet lamp from the packing carton. Slowly and carefully slide the lamp into the quartz sleeve. Attach the ultraviolet lamp socket and ensure that the socket is pushed all the way down to the base of the lamp for proper contact.

### b) Quartz Sleeve Cleaning Procedure

Significant film or debris deposits formed on the quartz sleeves will impair the ability of the ultraviolet rays to penetrate through the quartz and into the water. To a great extent, your frequency of cleaning will depend upon the water quality. The more minerals present in the water, the more frequently the quartz will require cleaning. A periodic visual inspection of the quartz will be necessary to determine the frequency of cleaning. Initial inspection should take place after thirty (30) days of operation. If the quartz is dirty, shorten the cleaning intervals. If the quartz is clean, lengthen the cleaning intervals.

To clean quartz sleeves, depressurize the unit by first turning off the inlet valve. Open a tap to relieve pressure and then turn off the outlet valve. Turn off the power to the ultraviolet system. Drain the vessel. Loosen the set screw on the compression nut and pull apart the compression cap from the compression nut. Slide the lamp out about 2 inches from the compression nut and remove the lamp connector from the lamp and then carefully remove the lamp. Unscrew the compression nuts from the nipples. Remove the o-rings and slide the quartz sleeve out of the unit, taking care to not let the quartz bump against any metal parts. The quartz sleeve may be cleaned with warm soapy water and rinsed thoroughly. If this is not sufficient, denatured alcohol may be used.

Assembly is the reverse of removal.

**NOTE: The lamp and quartz sleeve are fragile!**

**IMPORTANT: It is recommended to sanitize the entire system after servicing.**

(See "Plumbing System Sanitization Procedure" section of IOM Manual for instructions.)

**c) Lamp Recycling**

UV lamps need to be recycled like fluorescent lamps because they contain mercury. Please follow your local recycling laws. Visit [www.lamprecycle.org](http://www.lamprecycle.org) for help finding a recycling center in your area. In the event that you are unable to find a disposal location, contact your manufacturer's representative.

**d) Countdown Timer (Optional)**

The countdown timer is used as a reminder to replace the UV lamp in your system after 365 days (one year). When the time has lapsed, the timer will sound. After performing routine maintenance and replacing the UV lamp, press the reset button using the tip of a paper clip or something similar to start the next 365 day cycle. To replace the battery, you will need to pull apart the top cover from the bottom of the timer. Replace with a LR44 or similar type battery. Snap the cover back on to the bottom and reset.

## UVR SERIES REPLACEMENT PARTS



**Table 2 — Replacement Parts List**

Item No.	Description	UVR04	UVR07	UVR07U	UVR10	UVR15
1	Ballast	UVR-BALS		UVR-BALM or UVR-BALM-WP (Waterproof)		
2	Compression Nut	UVR-CN				
3	O-Ring EPDM	DI-ORNG0009				
4	Lamp	DI-LMPUVR04	DI-LMPUVR07		DI-LMP42053	DI-LMPUVR15
5	Quartz Sleeve	IL-UVR04Q	IL-UVR07Q		IL-UVR10Q	IL-UVR15Q
6	Mounting Bracket	UVR-MB				
7	Sight Glass	UVR-SG				
8	Timer Holder*	UVR-TH				
9	Countdown Timer*	UVR-CT				
10	UV Monitor**	N/A			UVR-MON	
11	Sensor Assembly**	N/A			UVR-SA	
Not Shown	Ballast Clip	UVR-BC				

\* For Timer (-T) models and Monitor (-M) models only.

\*\* For Monitor (-M) models only.

## TECHNICAL SPECIFICATIONS

**Table 3 — Flow Rate vs Disinfection Levels**

Dosage vs Flow Rate	UVR04	UVR07	UVR07U	UVR10	UVR15
Flow rate for UV dosage of 40 mJ/cm <sup>2</sup> at end of lamp life (9,000 hours-1 year)*	2 GPM	3.5 GPM	3.5 GPM	5 GPM	8 GPM
Flow rate for UV dosage of 30 mJ/cm <sup>2</sup> at end of lamp life (9,000 hours-1 year)*	2.5 GPM	5 GPM	5 GPM	8 GPM	11 GPM
Flow rate for UV dosage of 16 mJ/cm <sup>2</sup> at end of lamp life (9,000 hours-1 year)*	4 GPM	7 GPM	7 GPM	12 GPM	16 GPM

\* Flow rate based on 95% UVT for clear fresh water

### Dimensions and Specifications

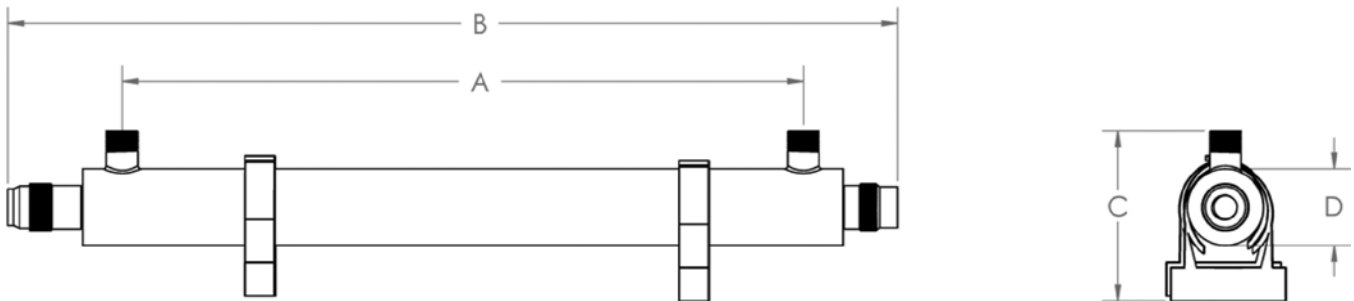

Model	Dimensions Inches				Inlet/Outlet	Operating Voltage
	A	B	C	D		
UVR04	10.23	16.40	4.25	2.5	1/2 inch MNPT	120V 60Hz
UVR07	17.32	23.25	4.25	2.5	3/4 inch MNPT	120V 60Hz
UVR07U	17.32	23.25	4.25	2.5	3/4 inch MNPT	100-240V 50/60Hz
UVR10	23.00	29.00	4.25	2.5	3/4 inch MNPT	100-240V 50/60Hz
UVR15	31.50	38.05	4.30	2.5	1 inch MNPT	100-240V 50/60Hz

**CAUTION:** Be sure to leave an unobstructed clearance on one end of the UV unit for the removal of the lamp and quartz sleeve. Recommended clearance is the length of the unit (Dimension D) plus 4 inches.

## TROUBLESHOOTING

Problem	Recommended Action
Unit is leaking	<ul style="list-style-type: none"> <li>• Check to see that compression nut is tight.</li> <li>• Verify that inlet pressure does not exceed 100 psi.</li> <li>• Verify o-ring is seated properly. Refer to “Quartz Sleeve Installation” section of IOM Manual.</li> <li>• Lubricate o-ring with food grade silicone.</li> <li>• Check o-ring for cracks or tears. Replace if necessary.</li> <li>• Check quartz sleeve for possible cracks or chips. Replace quartz sleeve if cracked or chipped.</li> </ul>
Poor bacterial performance	<ul style="list-style-type: none"> <li>• Replace lamp if it is more than 365 days old or nearing the end of its lamp life.</li> <li>• Perform routine maintenance.</li> <li>• Check water quality. If water quality has changed, take corrective action. Water supply cannot exceed maximum concentration levels as shown in Table 1 in “Preparation for Installing UV System” section of IOM Manual.</li> <li>• Verify flow rate vs disinfection levels as shown in Table 3 in “Technical Specifications” section of IOM Manual.</li> </ul>
Lamp Status LED is red	<ul style="list-style-type: none"> <li>• Lamp has failed. Replace lamp.</li> </ul>
Lamp Status LED is not glowing	<ul style="list-style-type: none"> <li>• Check for power at outlet. If power is present, replace ballast.</li> </ul>
Audible alarm sounds	<ul style="list-style-type: none"> <li>• Lamp has failed. Replace lamp.</li> </ul>
Power fails	<ul style="list-style-type: none"> <li>• Unit will restart automatically when power is restored.</li> <li>• The unit is designed for continuous operation. Never connect the unit to a timer or other device which will cause the unit to cycle on and off. Excessive cycling will reduce lamp life.</li> </ul>
Low UV Monitor reading (Less than 85% transmission)  <i>Models UVR10-M and UVR15-M only</i>	<ul style="list-style-type: none"> <li>• Check water quality. Ensure that color, turbidity, and iron content are within normal parameters.</li> <li>• Ensure input voltage matches requirements.</li> <li>• Verify lamp is on and less than 1 year old.</li> <li>• Replace old or defective lamp.</li> <li>• Clean quartz sleeve.</li> <li>• Clean UV sensor lens.</li> <li>• If reading is at 0%, ensure UV sensor cable is connected.</li> </ul>

If questions still remain after completing a troubleshooting procedure, please contact the manufacturer.

