

# MODEL 5000SE

*Upflow Brining*

*Service Manual*



**IMPORTANT:** Fill in pertinent information on page 2 for future reference.

# MODEL 5000SE Upflow

---

## *Job Specification Sheet*

---

Job Number \_\_\_\_\_

Model Number \_\_\_\_\_

Water Test \_\_\_\_\_

Capacity Of Unit \_\_\_\_\_ Max. \_\_\_\_\_ Per Regeneration

Mineral Tank Size: Diameter \_\_\_\_\_ Height \_\_\_\_\_

Under Bedding \_\_\_\_\_ Amount \_\_\_\_\_

Type Of Media \_\_\_\_\_ Cubic Feet \_\_\_\_\_

Brine Tank Size \_\_\_\_\_

Salt Setting Per Regeneration \_\_\_\_\_

### **Valve Programming**

Treated Water Capacity \_\_\_\_\_ (Gallons / Liters/m<sup>3</sup>)

Regeneration Day Override \_\_\_\_\_ (Max. Days Between Regen.)

Regeneration Time \_\_\_\_\_ ( A.M. ) ( P.M. )

### **Notes:**

---

---

---

---

---

---

---

---

---

---

# MODEL 5000SE Upflow

---

## *General Residential Installation Check List*

---

**WATER PRESSURE:** A minimum of 20 psi inlet water pressure is required for regeneration valve to operate effectively

**ELECTRICAL FACILITIES:** An uninterrupted alternating current (A/C) supply is required. Please make sure your voltage supply is compatible with your unit before installation.

**EXISTING PLUMBING:** Condition of existing plumbing should be free from lime and iron buildup. Piping that is built up heavily with lime and/or iron should be replaced. If piping is clogged with iron, a separate iron filter unit should be installed ahead of the water softener.

**LOCATION OF SOFTENER AND DRAIN:** The softener should be located close to a clean working drain and connected according to local plumbing codes.

**BY-PASS VALVES:** Always provide for the installation of a by-pass valve if unit is not equipped with one.

**CAUTION:** Water pressure is not to exceed 120 p.s.i., water temperature is not to exceed 110°F, and the unit cannot be subjected to freezing conditions.

---

## *Valve Installation and Start-up Procedures*

---

### INSTALLATION INSTRUCTIONS

1. Place the softener tank where you want to install the unit, making sure the tanks are level and on a firm base.
2. All plumbing should be done in accordance with local plumbing codes. The pipe size for the drain line should be a minimum of 1/2". Backwash flow rates in excess of 7 gpm or length in excess of 20' require 3/4" drain line.
3. The 1" distributor tube (1.050 O.D.) should be cut flush with top of tank.
4. Lubricate the distributor o-ring seal and tank o-ring seal. Place the main control valve on tank. Note: Only use silicone lubricant.
5. Solder joints near the drain must be done prior to connecting the Drain Line Flow Control fitting (DLFC). Leave at least 6" between the DLFC and solder joints when soldering pipes that are connected on the DLFC. Failure to do this could cause interior damage to the DLFC.
6. Teflon tape is the only sealant to be used on the drain fitting.
7. Make sure that the floor is clean beneath the salt storage tank and that it is level.
8. On units with a by-pass, place in by-pass position. Turn on the main water supply. Open a cold soft water tap nearby and let run a few minutes or until the system is free from foreign material (usually solder) that may have resulted from the installation. Once clean, close the water tap.
9. Place the by-pass in service position and let water flow into the mineral tank. When water flow stops, slowly open a cold water tap nearby and let run until the air is purged from the unit.
10. Plug unit into an electrical outlet. Note: All electrical connections must be connected according to local codes.
11. Add water to the top of the air check. Manually step the valve to the Brine Draw Position and allow the valve to draw water from the brine tank until it stops. Note: The air check will check at approximately the midpoint of the screened intake area.
12. Next, manually step the valve to the Brine Refill Position and allow the valve to return to Service automatically.
13. With the valve in Service, check that there is about 1.0" of water above the grid in the brine tank, if used.
14. Fill the brine tank with salt.
15. Set-Up is now finished, the control can now be left to run automatically.

# MODEL 5000SE Upflow

## Master Programming Mode Flow Chart

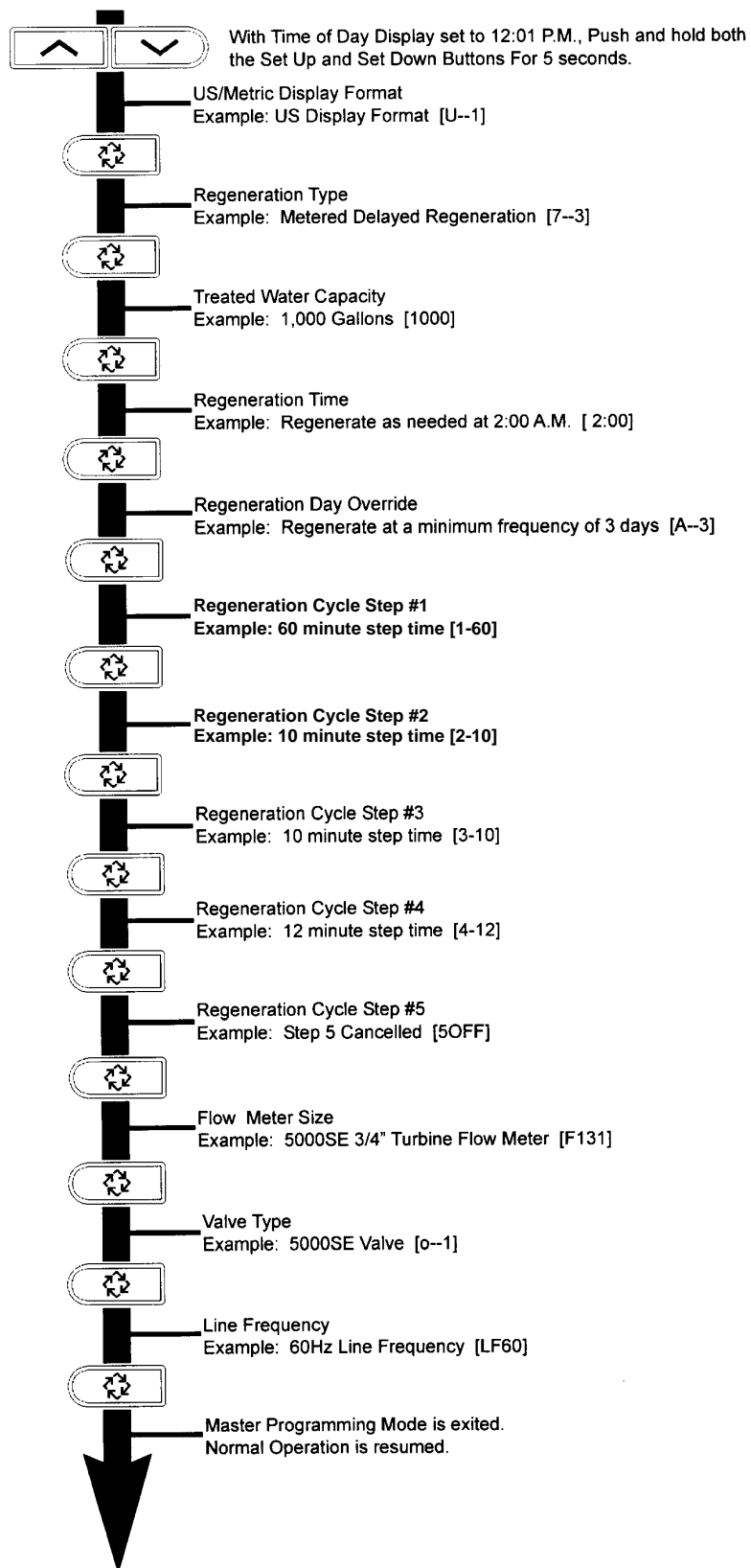

**Note:**

1. Set Time Of Day Display To 12:01 P.M.
2. Push And Hold The Set Up And Set Down Button For 5 Seconds.
3. Push Extra Cycle Button Once Per Display Until All Displays Are Viewed And Normal Operation Is Resumed.
4. Option Setting Displays May Be Changed As Required By Pushing Either The Set Up Or Down Button.
5. Depending On Current Valve Programming Certain Displays Will Not Be Able To Be Viewed Or Set.

# MODEL 5000SE Upflow

## Control Start-Up Procedures

Whenever the valve is in *Service* the current time of day can be set, the control programmed, or an extra regeneration initiated at any time.

### 1. Set Time Of Day

#### Service Indicator:

Valve In Service - Dot On  
Extra Cycle Tonight - Flashing Dot

Set Up Button

Set Down Button

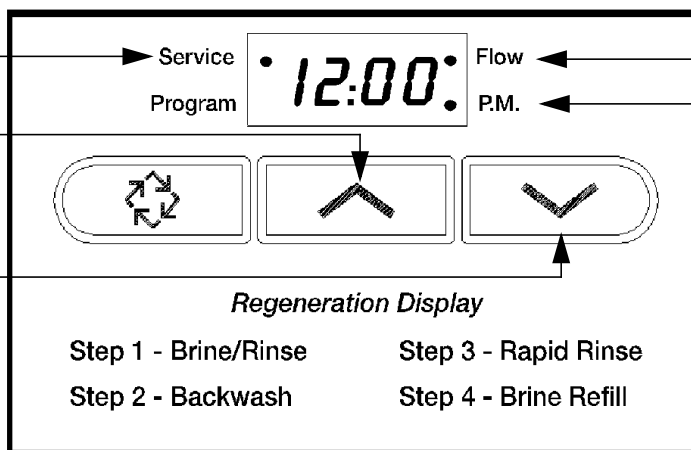

#### Flow Indicator:

Flashing Dot With Water Flow

P.M. Indicator

### 2. Enter Control Programming Mode

#### Program Mode Indicator:

Program Mode Entered - Dot On

Extra Cycle Button

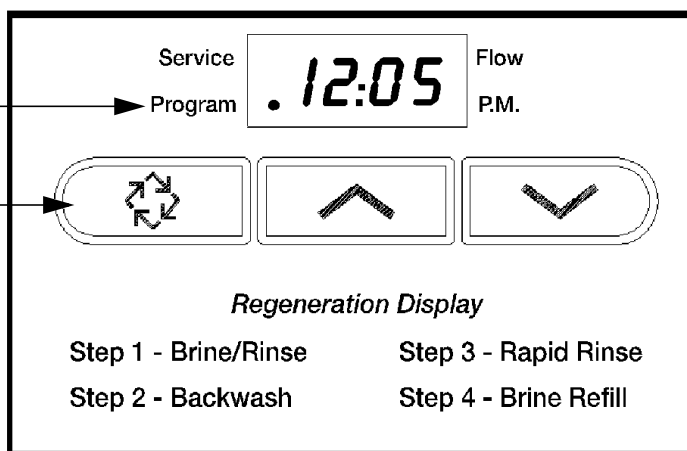

1. Push and hold for 5 seconds *both* the Up and Down Set Buttons to enter Programming Mode.
2. Push the *Extra Cycle Button* once per display until all have been viewed and this mode is exited and normal operation is resumed.

# MODEL 5000SE Upflow

## Control Start-Up Procedures (Cont'd.)

Depending on current control programming, option setting displays that are not required to be set will not be viewed.

### 3. Set Control Programming

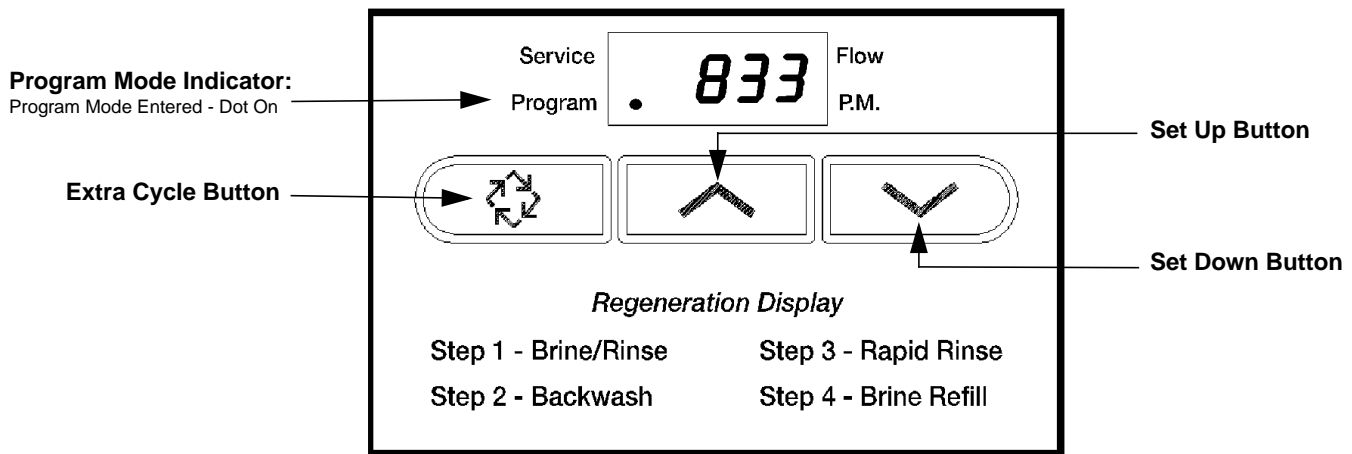

1. The first option setting display that appears in the Program Mode is Treated Water Capacity. Using the Set Up or Down Buttons, set the amount of treated water that can flow through the unit before a regeneration is required. For Example:

650 Gallons Capacity

Service Flow  
Program . 650 P.M.

2. Push the Extra Cycle Button. The second option setting display that appears is Regeneration Time. Using the Set Up or Down Buttons, set the desired time of day when a regeneration can occur, if required. For Example:

2:00 A.M. Regeneration Time

Service Flow  
Program . 2:00 P.M.

3. Push the Extra Cycle Button. The third option setting display that appears is Regeneration Time. Using the Set Up or Down Buttons, set the maximum number of days before a regeneration cycle must occur. For Example:

Regenerate Every  
7 Days Minimum

Service Flow  
Program . A--7 P.M.

4. Control programming is now complete. Push the Extra Cycle Button. This will exit the control from the Programming Mode, and resume Normal Operation.

# MODEL 5000SE Upflow

## Control Start-Up Procedures (Cont'd.)

### 4. Start An Immediate Extra Cycle

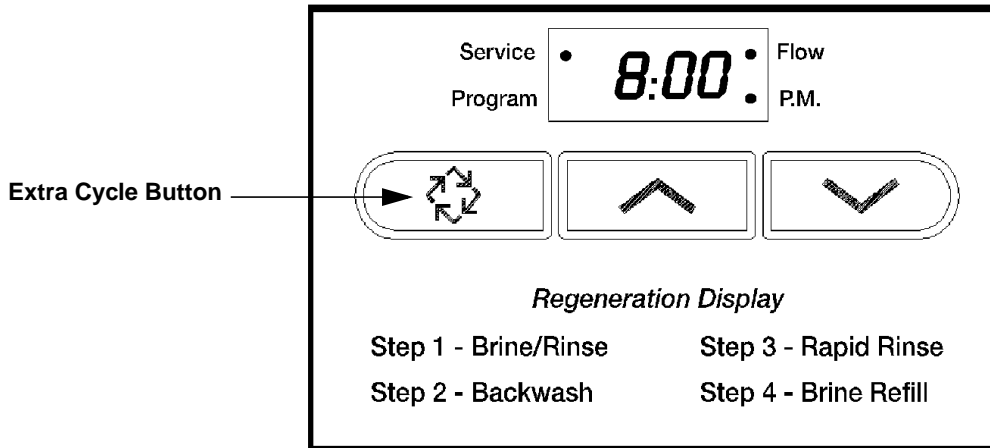

When starting an Extra Cycle, you will have one or two options:

**1. Press and Release the Extra Cycle Button:**

- With *Immediate Regeneration* controls the control will go into regeneration cycle immediately.
- With *Delayed Regeneration* controls the Service Arrow will begin to flash immediately and a regeneration will occur at the present regeneration time (i.e. 2:00 a.m.)

**2. Press and Hold for 5 seconds the Extra Cycle Button:**

- With *Delayed Regeneration* controls, the control will go into regeneration cycle immediately.

### 5. Regeneration Cycle Displays

The following series of displays appear when the control enters a regeneration cycle:

Valve Driving To Regen. Step #1	Service Program	1 - - -	Flow P.M.	Then	Service Program	1 - 58	Flow P.M.	Less Than 59 Min. Remain In Regen. Step #1
Valve Driving To Regen. Step #2	Service Program	2 - - -	Flow P.M.	Then	Service Program	2 - - 8	Flow P.M.	Less Than 9 Min. Remain In Regen. Step #2
Valve Driving To Regen. Step #3	Service Program	3 - - -	Flow P.M.	Then	Service Program	3 - - 8	Flow P.M.	Less Than 9 Min. Remain In Regen. Step #3
Valve Driving To Regen. Step #4	Service Program	4 - - -	Flow P.M.	Then	Service Program	4 - 1 1	Flow P.M.	Less Than 12 Min. Remain In Regen. Step #4
Regen. Complete. Valve Driving To Service	Service Program	- - - -	Flow P.M.	Then	Service Program	• 8:00 •	Flow P.M.	Valve Has Returned To Service

# MODEL 5000SE Upflow

## Control Start-Up Procedures (Cont'd.)

### 6. Fast Cycle Valve Thru Regeneration

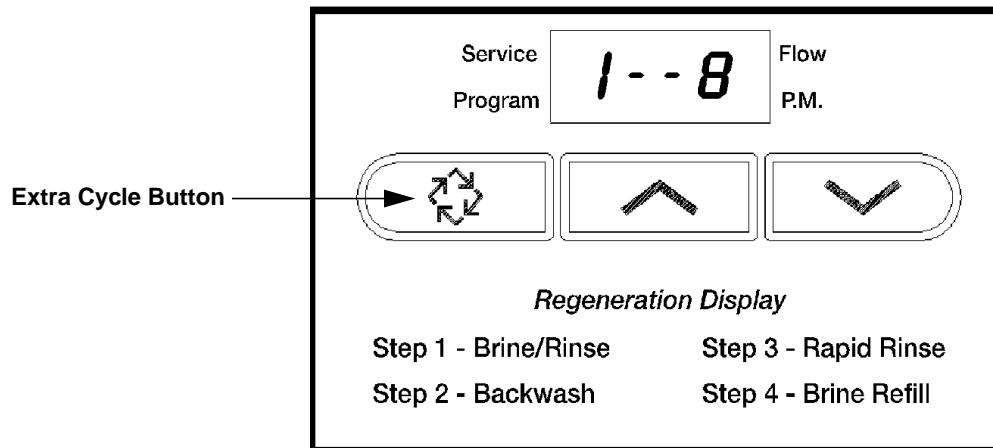

- A. Once the valve reaches Regen Step #1 let water run to drain for about 5 minutes. Next, manually step the valve through a regeneration cycle checking valve operation in each step:
- B. Push the Extra Cycle Button once to advance the valve to Regen Step #2.
- C. Push the Extra Cycle Button once to advance the valve to Regen Step #3. (Optional)
- D. Push the Extra Cycle Button once to advance the valve to Regen Step #4. (Optional)
- E. Push the Extra Cycle Button once more to advance the valve back to Service.

### 7. Final Set-Up

With proper valve operation verified:

- A. Add water to the top of the air check. Manually step the valve to the Brine Draw Position and allow the valve to draw water from the brine tank until it stops. Note: The air check will check at approximately the midpoint of the screened intake area.
- B. Next, manually step the valve to the Brine Refill Position and allow the valve to return to Service automatically.
- C. With the valve in Service, check that there is about 1.0" of water above the grid in the brine tank, if used.
- D. Fill the brine tank with salt.
- E. Set-Up is now finished, the control can now be left to run automatically.



# MODEL 5000SE Upflow

## Control Operation

### Timeclock Regeneration Valves

In normal operation the Time Of Day Display will be viewed at all times. The control will operate normally until the number of days since the last regeneration reaches the Regeneration Day Override setting. Once this occurs, a regeneration cycle will then be initiated at the preset Regeneration Time.

### Flow Meter Equipped Valves

In normal operation the Time Of Day Display will alternate being viewed with a Volume Remaining Display. This display will be in gallons. As treated water is used, the Volume Remaining Display will count down from a maximum value to zero or (---). Once this occurs a regeneration cycle will then be initiated immediately or delayed to the set Regeneration Time. Water flow through the valve is indicated by the Flow Dot that will flash in a direct relationship to flow rate. For Example:

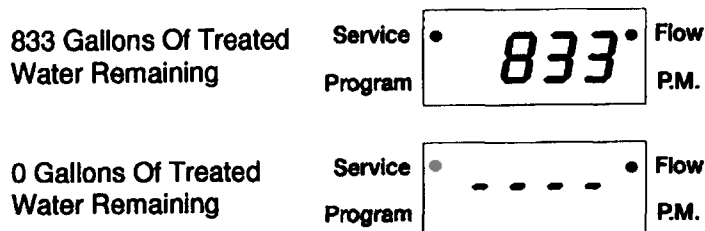

### Immediate Regeneration Valves With Days Between Regeneration Override Set

When the valve reaches its set Days Since Regeneration Override value a regeneration cycle will be initiated immediately. This event occurs regardless of the Volume Remaining display having reached zero gallons.

### Delayed Regeneration Valves With Days Between Regeneration Override Set

When the valve reaches its set Days Since Regeneration Override value a regeneration cycle will be initiated at the preset Regeneration Time. This event occurs regardless of the Volume Remaining display having reached zero gallons.

---

### Control Operation During Regeneration

In Regeneration the control will display a special *Regeneration Display*. In this display the control will show the current regeneration step number the valve is advancing to, or has reached, and the time remaining in that step. The step number displayed will flash until the valve has completed driving to this regeneration step position. Once all regeneration steps have been completed the valve will return to Service and resume normal operation. For Example:



Pushing the Extra Cycle Button during a regeneration cycle will immediately advance the valve to the next cycle step position and resume normal step timing.

### Control Operation During Programming

The control will only enter the Program Mode with the valve in Service. While in the Program Mode the control will continue to operate normally monitoring water usage and keeping all displays up to date. Control programming is stored in memory permanently, without the need for battery backup power.

### Control Operation During A Power Failure

During a power failure all control displays and programming will be stored for use upon power re-application. *The control will retain these values for years, if necessary, without loss.* The control will be fully inoperative and any calls for regeneration will be delayed. The control will upon power re-application resume normal operation from the point were it was interrupted. *An indication that a power outage has occurred will be an inaccurate time of day display.*

# MODEL 5000SE Upflow

## Master Programming Mode

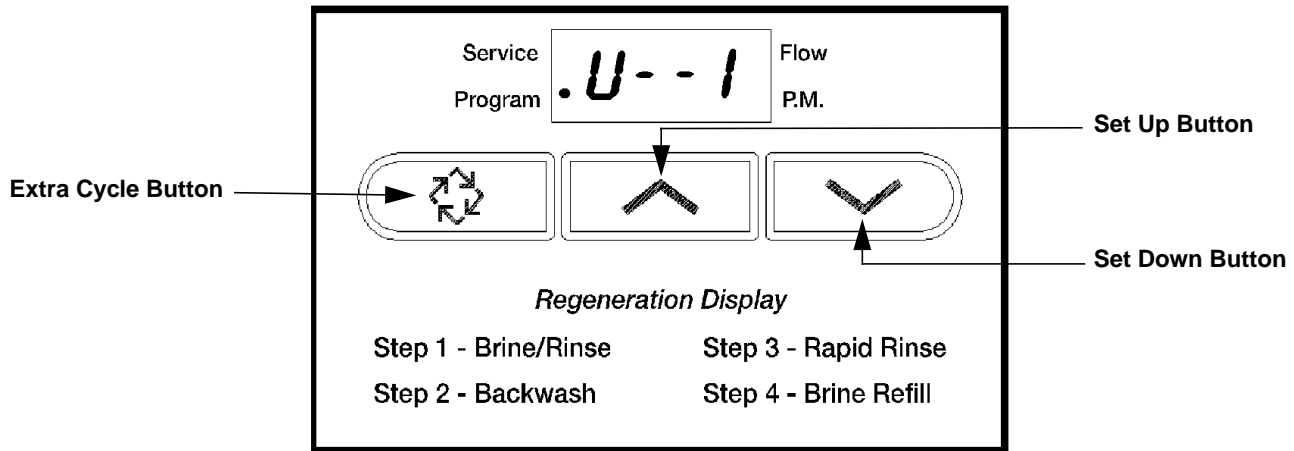

### Entering Master Programming Mode

With the Time of Day Display set to 12:01 P.M., push and hold for 5 seconds both the Set Up and Set Down Buttons. The Program Indicator will turn on to signal that this mode is entered. In this mode all possible option settings may be viewed.

#### 1. US/Metric Display Format (U)

This display is used to set the desired display format. This option setting is identified by the letter (U) in the first digit. There are three possible settings:

Example: [ U - - 1 ] for US gallons

Metric format uses liters or cubic meters with a 24-hour timekeeping format. Regeneration timing in tenths of minutes.

Example: [ U - - 2 ] for liters

[ U - - 4 ] for cubic meters

The **SET UP** or **DOWN** buttons will adjust this value.

Depress the Extra Cycle Button to proceed to the next step.

#### 2. Regeneration Type (7)

Depress the Extra Cycle Button. This display is used to set the Regeneration Type. This option setting is identified by the number 7 in the first digit. There are 3 possible settings:

**Timeclock Delayed.** The control will determine that regeneration is required when the set Regeneration Time has been reached. The Regeneration Day Override setting will determine which days a regeneration cycle will be initiated.

Example: [ 7 - - 1 ]

**Meter Immediate.** The control will determine that regeneration is required when the available volume of softened water drops to or below zero. Regeneration to begin immediately.

Example: [ 7 - - 2 ]

# MODEL 5000SE Upflow

---

## Master Programming Mode (Cont'd.)

---

### 2. Regeneration Type (7) (Cont'd.)

**Meter Delayed.** The control will determine that a regeneration is required when the available volume of softened water drops to or below zero. Regeneration is to begin immediately at the set Regeneration Time.

Example: [ 7 - - 3 ]

The **Set UP** and **DOWN Buttons** will adjust this value.

### 3. Treated Water Capacity (No Display Code)

Depress the Extra Cycle Button. This display is used to set the amount of treated water (gallons/liters) that can be produced by the unit before a regeneration cycle is required. With Meter Delayed Regeneration Type set, it will be up to the programmer to determine a reserve capacity and subtract that value from the calculated full capacity of the unit. This display will not be viewed with Timeclock Regeneration Type set.

Example: Regenerates every 700 gallons or liters - [ 7 0 0 ]

The **Set UP** and **DOWN Buttons** will adjust this value.

### 4. Regeneration Time (No display Code)

Depress the Extra Cycle Button. The next display viewed is the option setting for Regeneration Time. It is identified by a non-flashing colon between two sets of numbers. Set the desired time of day that a regeneration may occur, if required. This display will not be viewed with Meter Immediate Regeneration Type set.

Example: 2 o'clock A.M. regeneration time - [ 2 : 0 0 ] (A.M. Indicator Dot On)

The **Set UP** and **DOWN Buttons** will adjust this value.

### 5. Regeneration Day Override (A)

Depress the Extra Cycle Button. This display is used to set the maximum amount of time (in days) the unit can be in service without a regeneration. This option setting is identified by the letter 'A' in the first digit. With Meter Immediate Regeneration Type selected, regeneration will begin at the same point in time some amount of days ago when the last regeneration cycle was initiated. With Timeclock or Meter Delayed Regeneration Types selected, regeneration begins at the set Regeneration Time. An OFF setting will cancel this feature with all regeneration types except Timeclock Regeneration were it must be used.

Example: Override every 7 days - [ A - - 7 ]

Cancel setting - [ A O F F ] (Meter Immediate or Delayed Regeneration Types Only)

The **Set UP** and **DOWN Buttons** will adjust this value.

### 6. Regeneration Cycle Step Programming (1) (2) (3) (4) (5) (6)

Depress the Extra Cycle Button. The next 2-4 displays viewed are part of a series of option settings used to program the Regeneration Cycle. Up to 4 steps can be programmed. Each display is used to set the duration time in minutes (or tenths of minutes - Metric) of that specific step in a regeneration cycle. A step # will turn on for the regeneration cycle step being programmed. Regeneration steps are *skipped* by setting the display to 0 and regeneration *ended* by setting the step # after the last active step to OFF, as shown below and on the next page:

Examples: Regeneration Cycle Step #1 - 8 minutes - [ 1 - - 8 ]

Regeneration Cycle Step #3 - skipped - [ 3 - - 0 ]

Example: lbs. salt ÷ 3 ÷ B.L.F.C. Size = refill time in minutes, 10 lbs. salt ÷ 3 ÷ .25 = 13.3 minute refill

The **Set UP** and **DOWN Buttons** will adjust these values.

# MODEL 5000SE Upflow

---

## *Master Programming Mode (Cont'd.)*

---

### 7. Flow Meter Size (F)

Depress the Extra Cycle Button. The next display is used to set the flowmeter size. This option setting is identified by the letter F in the first digit. In this display set the proper amount of pulses generated by the flow meter for each gallon or liter of water flow. This setting will not be viewed with Timeclock Regeneration Type selected.

Examples: [ F 1 3 1 ] 3/4" Turbine Flow Meter (US Format)

[ F 3 4.6 ] 3/4" Turbine Flow Meter (Metric Format)

The **Set UP** and **DOWN Buttons** will adjust this value.

### 8. Valve Type (o)

Depress the Extra Cycle Button. This display is used to set the type of valve used with the control. This option setting is identified by the letter o in the first digit. There are two possible selections with #1 being the required setting.

Examples: [ o - - 1 ] 5000SE Valve Operation

[ o - - 2 ] Option Not Typically Used

The **Set UP** and **DOWN Buttons** will adjust this value.

### 9. Line Frequency (LF)

Depress the Extra Cycle Button. This display is used to set the frequency of the power applied to the control. When properly set, all timekeeping functions will remain accurate. This option setting is identified by the letters LF in the first digit. There are two possible selections.

Examples: [ L F 5 0 ] 50Hz Line Frequency Operation

[ L F 6 0 ] 60Hz Line Frequency Operation

The **Set UP** and **DOWN Buttons** will adjust this value.

### Exiting This Option Setting Level

Push the Extra Cycle Button once per display until all have been viewed. The Program Mode will be exited and normal operation resumed.

### Resetting Permanent Programming Memory -

Push and hold the Set Up and Down Buttons for 25 seconds or until the Time Of Day Display resets to 12:00 P.M. All option setting will then reset to the default values. Control programming will then have to be reset as necessary.

# MODEL 5000SE Upflow

## Dimensional Drawing

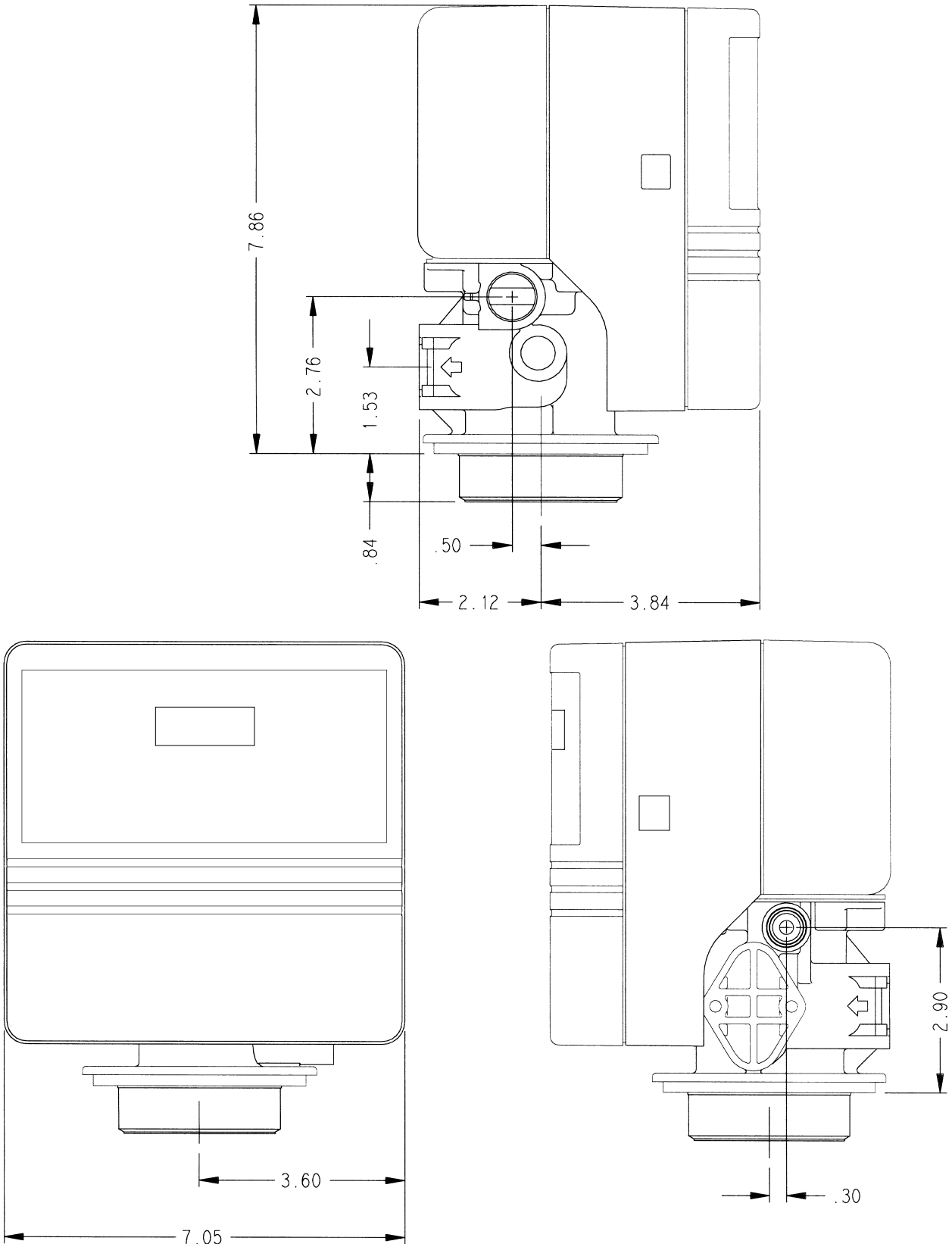

# MODEL 5000SE Upflow

## Water Conditioner Flow Diagrams

### Service Position

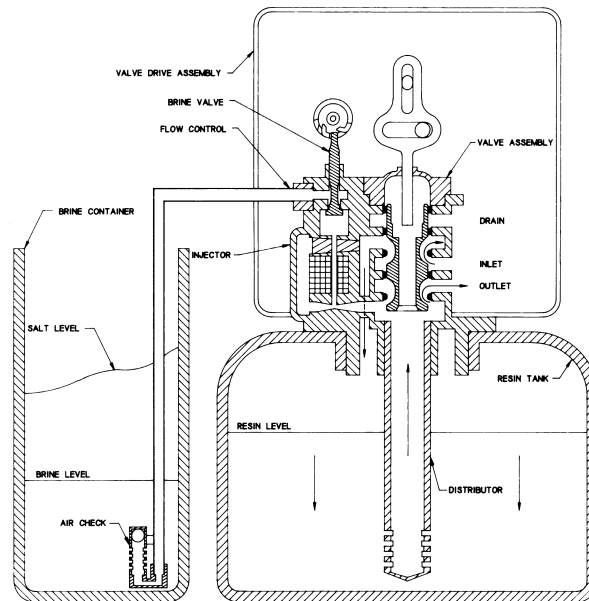

Hard water enters unit at valve inlet and flows around the piston down thru the mineral in the mineral tank. Conditioned water enters center tube thru the bottom distributor then flows up thru the center tube and to the outlet of the valve.

### 1 Brine Draw/Slow Rinse Position

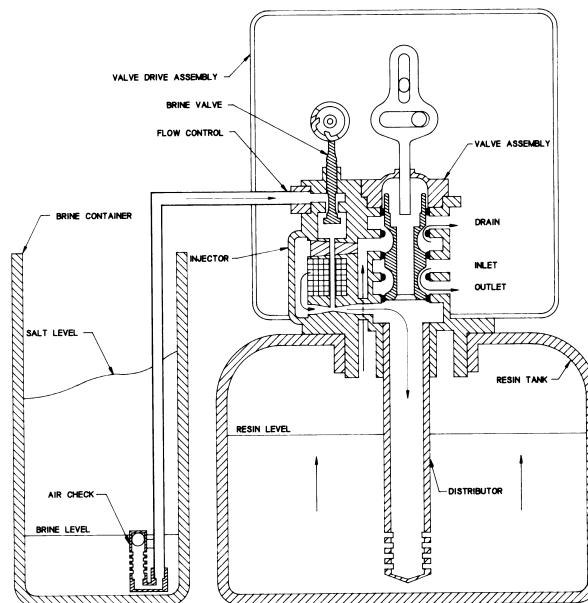

**Brine.** Hard water enters unit at valve inlet - flows into injector housing and thru nozzle and throat to draw brine from the brine tank - brine flows down thru the center tube and up thru the mineral and out thru the drain line.

**Slow Rinse.** Hard water enters unit at valve inlet - flows into injector housing and thru nozzle and throat down thru the center tube and up thru the mineral and out thru the drain line.

# MODEL 5000SE Upflow

## Water Conditioner Flow Diagrams (Cont'd.)

### 2 Backwash

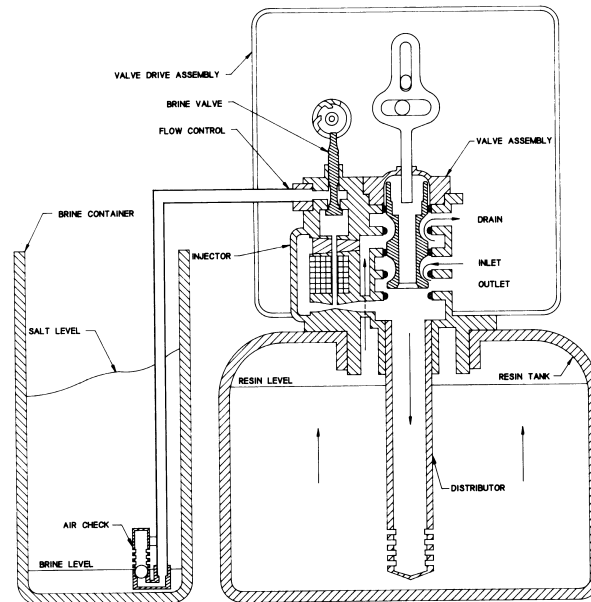

Hard water enters unit at valve inlet - flows around piston - down center tube - thru bottom distributor and up thru the mineral - around the piston and out the drain line.

### 3 Rapid Rinse Position

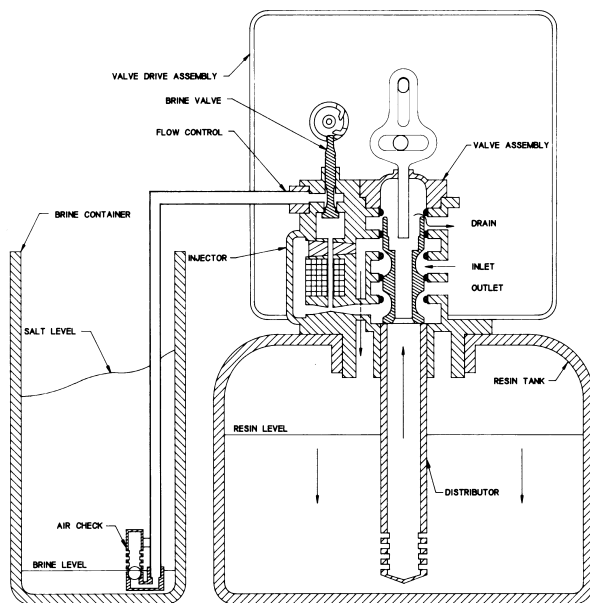

Hard water flows from inlet around the piston down thru the mineral into bottom distributor and up thru center tube - thru piston and out thru the drain line.

### 4 Brine Tank Fill Position

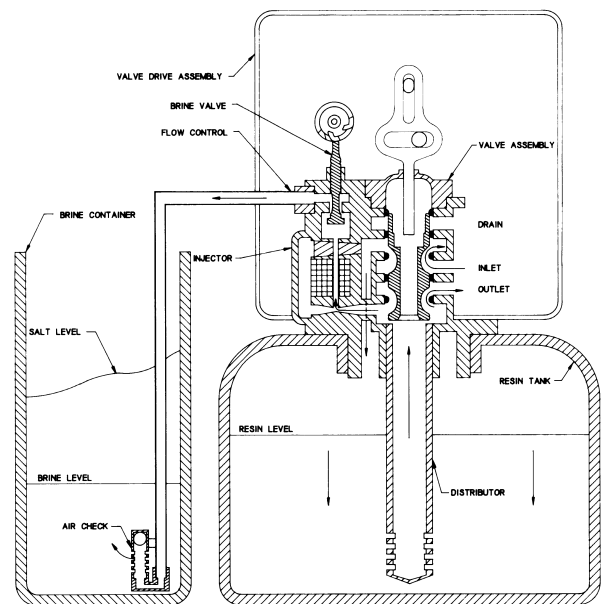

Hard water enters unit at valve inlet and flows around the piston down thru the mineral. Conditioned water flows up thru the center tube - flows thru the injector housing - thru the brine valve to fill the brine tank.

# MODEL 5000SE Upflow

## Valve Powerhead Assembly

(See opposite page for parts list)

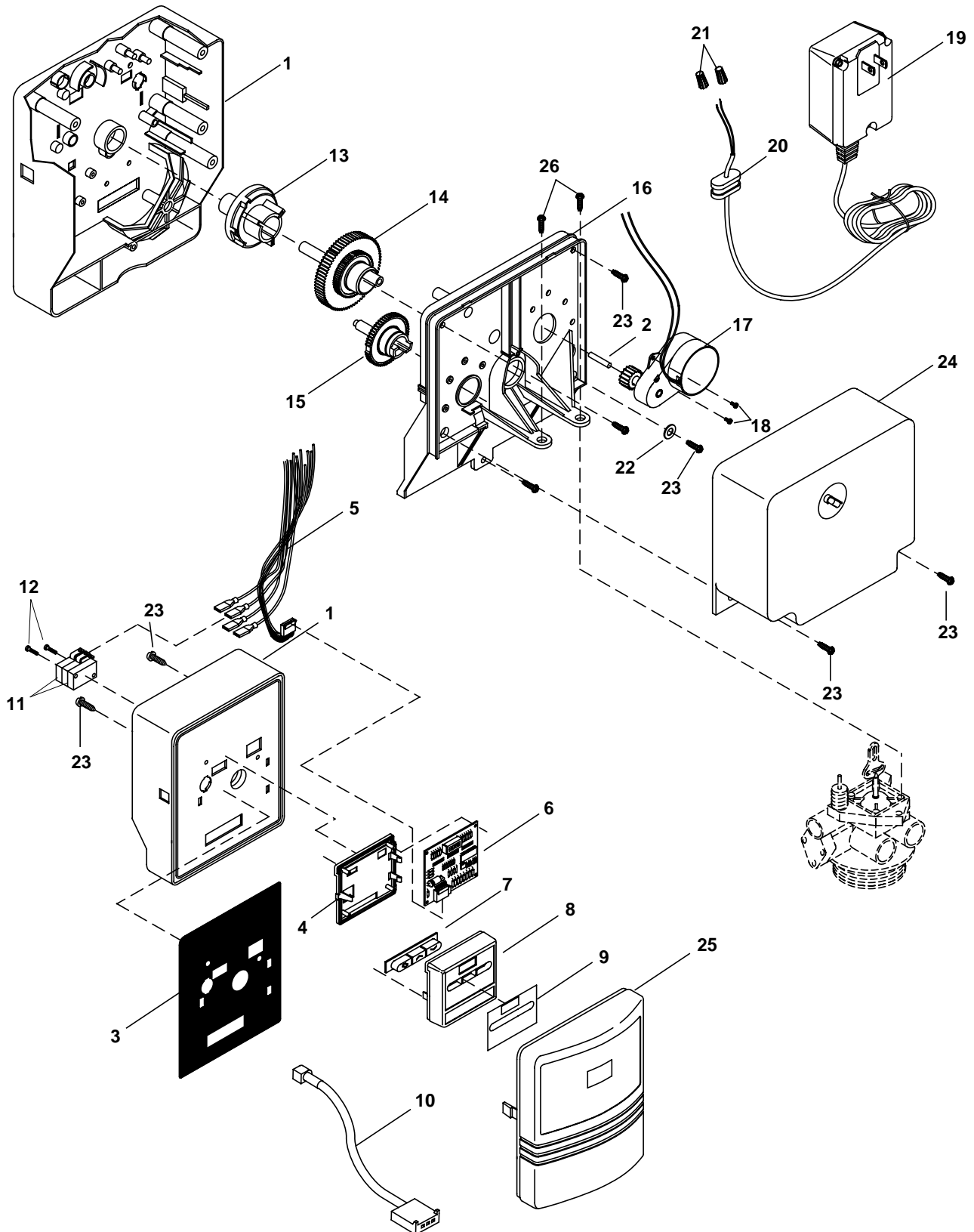



# MODEL 5000SE Upflow

## Valve Powerhead Assembly

### Parts List

Item No.	Quantity	Part No.	Description
1.....	1 .....	18201-025.....	Plate, Front
2.....	1 .....	18655 .....	Pin
3.....	1 .....	40248 .....	Label, Cover-up
4.....	1 .....	19889-01.....	Housing, Circuit Board
5.....	1 .....	19474 .....	Harness, Power
6.....	1 .....	40283 .....	Circuit Board, SE Timer
7.....	1 .....	19473 .....	Button, Conductive
8.....	1 .....	19471-02.....	Cover, Front Panel
9.....	1 .....	19697-02.....	Label, Display
10.....	1 .....	19791-01.....	Meter Cable Assy., Turbine
11.....	2 .....	10218 .....	Switch, Micro
12.....	2 .....	40081 .....	Screw #4-40 x 1.125
13.....	1 .....	19928 .....	Cam, Switch Upflow
14.....	1 .....	18251-01.....	Gear, Main Upflow
15.....	1 .....	18252 .....	Cam, Brine, Upflow
16.....	1 .....	18202-03.....	Back Plate
17.....	1 .....	40251 .....	Motor Assy., 24V 50Hz
18.....	2 .....	13602 .....	Screw, Rd. Hd. 6-33 x 5/16
19.....	1 .....	19674 .....	Transformer U.S. 24V (120V)
	1 .....	25651 .....	Transformer European 24V (230V)
20.....	1 .....	13547 .....	Strain Relief
21.....	4 .....	12681 .....	Nut, Wire, Beige
22.....	1 .....	13363 .....	Washer, Plain, .145 I.D.
22.....	1 .....	18259-02.....	Cover, Back Black
23.....	8 .....	13296 .....	Screw, Hex Washer 6-20 x 1/2
25.....	1 .....	18260-00.....	Cover, Front Smoke
26.....	2 .....	18261 .....	Screw, Hex Head, 10-24 x 13/16
Not Shown....	1 .....	14044 .....	Cable Tie

# MODEL 5000SE Upflow

## Control Valve Assembly

(See opposite page for parts list)

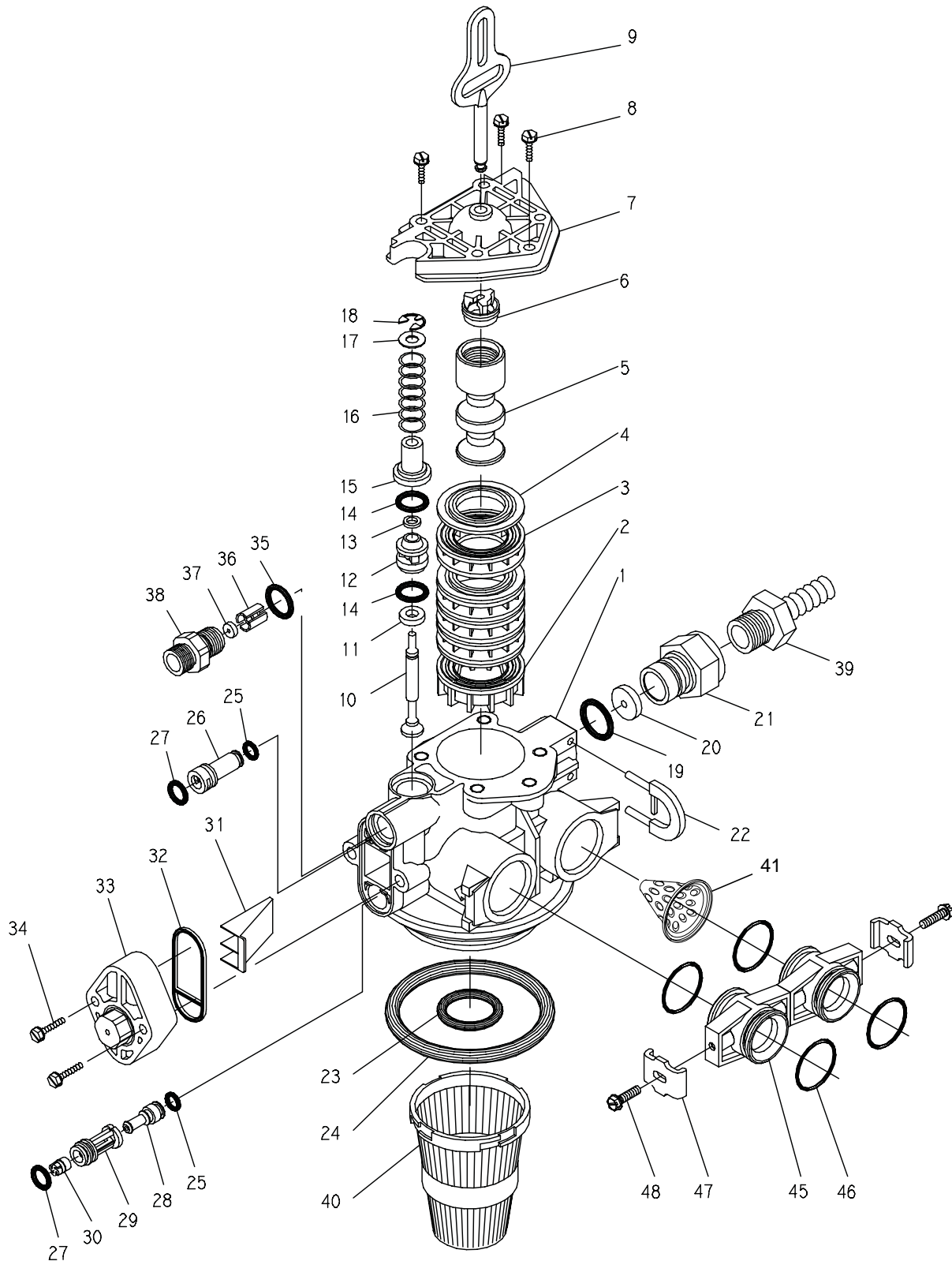

# MODEL 5000SE Upflow

## Control Valve Assembly

### Parts List

Item No.	Quantity	Part No.	Description
1	1	18815	Valve Body, 5000, 1", Dist.
		18815-20	Valve Body, 5000, w/ mixing
2	1	18264	Spacer, End
3	4	14241	Spacer
4	5	13242	Seal
5	1	18266	Piston, Up-flow
6	1	14309	Retainer, Piston Rod
7	1	18268	End Plug Assembly
8	3	18261	Screw, Hex Washer Head, 10-24 x 13/16
9	1	18267	Piston Rod
10	1	17978	Brine Valve Stem
11	1	18755	O-Ring, -201
12	1	13167	Spacer, Brine Valve
13	1	12550	Quad Ring, -009
14	2	13302	O-Ring, -014
15	1	13165	Cap, Brine Valve
16	1	11973	Spring, Brine Valve
17	1	16098	Washer, Plain, Nylon
18	1	11981-01	Retaining Ring
19	1	11183	O-Ring, -017
20	1		Flow Washer (specify size)
21	1	11385-01	Flow Control Housing, Plastic
22	1	18312	Retainer, Drain
23	1	13304	O-Ring, -121
24	1	18303	O-Ring, -336
25	2	10141	O-Ring, -010
26	1	18276	Plug, Injector, Softener
27	2	13771	O-Ring, -012
28	1	18275-X	Injector Throat (specify size) 0000, 000, 00, 0, 1, 2
29	1	18274-X	Injector Nozzle (specify size) 0000, 000, 00, 0, 1, 2
30	1	18273	Vortex Generator
31	1	18271	Screen Injector
32	1	18279	Seal, Injector
33	1	18278-20	Cap, Regulated Injector, 20 PSI, Black
	1	18278-30	Cap, Regulated Injector, 30 PSI, Gray
34	2	18262	Screw, Hex Washer Head, 10-24 x 1
35	1	12977	O-Ring, -015
36	1	13245	Retainer, BLFC Button
37	1		Flow Washer (specify size)
38	1	13244	Adapter, BLFC
39	1	13308	Hose Barb, Black, 1/2 x 1/2 Straight
	1	12338	Hose Barb, Black, 1/2 x 1/2 90° Elbow
40	1	18280	Top Collector, 1", X .011, Gray
	1	18280-01	Top Collector, 1", X .020 White, Wide Slot
	1	18280-02	Top Collector, 1", X .008 Red, Narrow Slot
41	1	14613	Flow Straightener
<b>OPTION</b>			
<b>Adapter Coupling Day Clock Only</b>			
45	2	19228	Adapter Coupling
46	4	13305	O-Ring, -119
47	2	13255	Clip, Mounting
48	2	13314	Screw, Hex Washer Head 8-18 x 5/8

# MODEL 5000SE Upflow

## 3/4" Turbine Meter Assembly

(See opposite page for parts list)

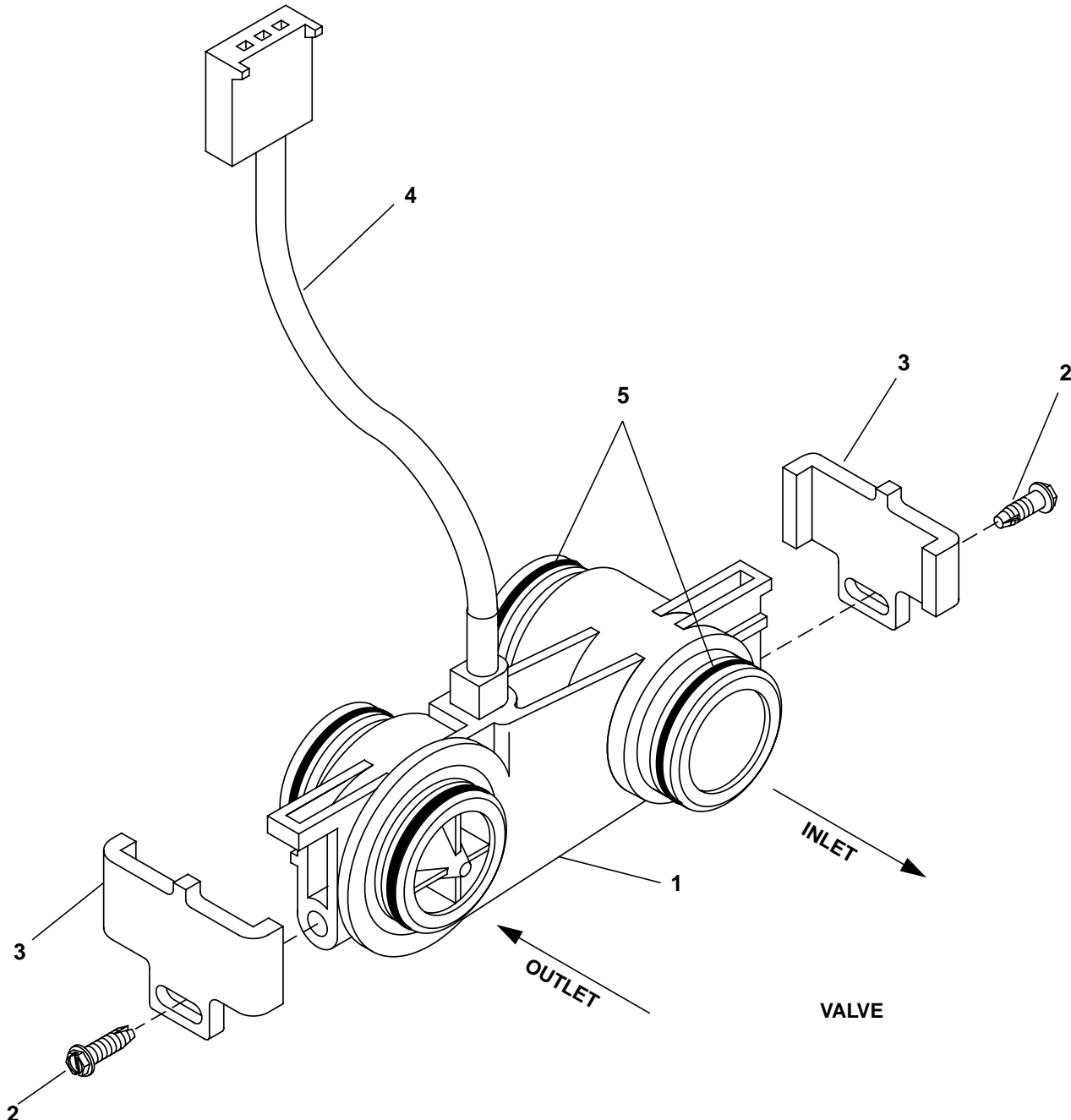

# MODEL 5000SE Upflow

---

## *3/4" Turbine Meter Assembly*

---

### *Parts List*

---

<b>Item No.</b>	<b>Quantity</b>	<b>Part No.</b>	<b>Description</b>
1.....	1 .....	19797 .....	Meter Body Assembly
2.....	2 .....	13314 .....	Screw, Hex Washer, 8-18 x 5/8"
3.....	2 .....	19569 .....	Clip, Flow Meter
4.....	1 .....	19791-01.....	Electrical Harness
5.....	4 .....	13305 .....	O-Ring, -119

# MODEL 5000

## 2310 Safety Brine Valve

(See opposite page for parts list)

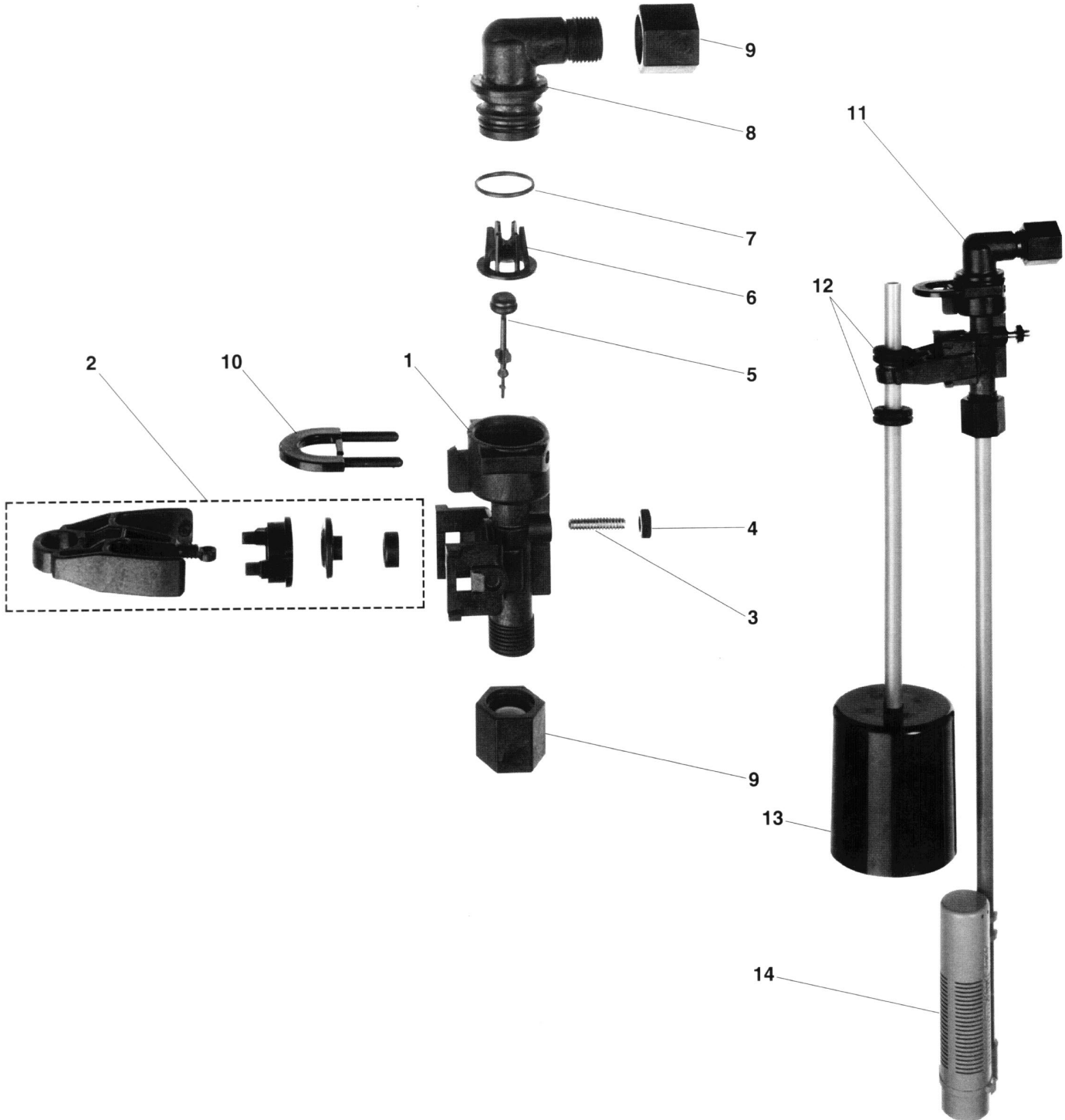

# MODEL 5000

---

## 2310 Safety Brine Valve (Cont'd.)

---

Item No.	Quantity	Part No.	Description
1.....	1 .....	19645 .....	Safety Brine Valve Body
2.....	1 .....	19803 .....	Safety Brine Valve Arm Assembly
3.....	1 .....	19804 .....	Stud, 10-24
4.....	1 .....	19805 .....	Nut, 10-24
5.....	1 .....	19652-01.....	Poppet & Seal
6.....	1 .....	19649 .....	Flow Dispenser
7.....	1 .....	11183 .....	O-Ring, -017
8.....	1 .....	19647 .....	Elbow, Safety Brine Valve
9.....	2 .....	19625 .....	Nut Assembly, 3/8
10.....	1 .....	18312 .....	Retaining Clip
11.....	1 .....	60014 .....	Safety Brine Valve, 2310 (includes items 1-10)
12.....	2 .....	10150 .....	Grommet (included with item 13)
13.....	1 .....	60068 .....	Float Assembly, 2310
14.....	1 .....	60002 .....	500 Air Check Assembly

# MODEL 5000SE Upflow

## By-Pass Valve Assembly, Plastic

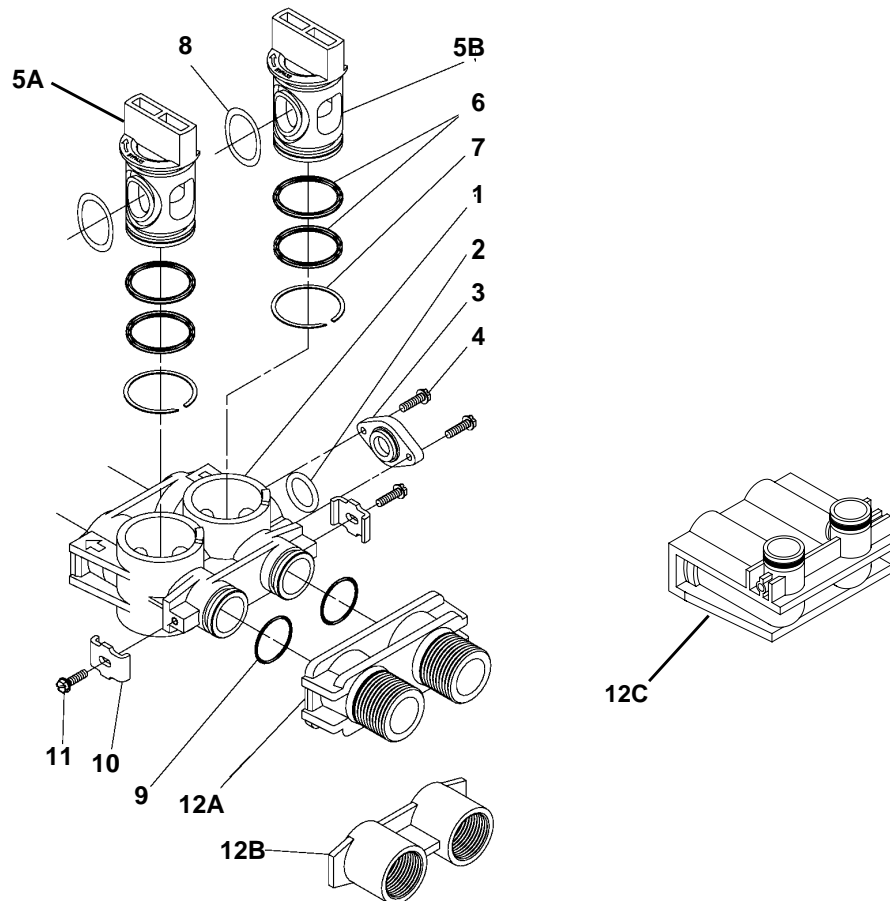

### Parts List

Item No.	Quantity	Part No.	Description
1	1	19723	By-Pass Valve Body, Plastic
2	1	11183	O-Ring, -015
3	1	19724	Cap, By-Pass
4	2	17512	Screw, Hex Washer Head, #6-24 x 3
5A	1	17820	Plug, By-Pass, Inlet
5B	1	17820-01	Plug, By-Pass, Outlet (White)
6	4	18661	O-Ring, -218
7	2	18662	Retaining Ring
8	2	18660	O-Ring
9	2	13305	O-Ring, -119
10	2	13255	Clip, Mounting
11	2	13314	Screw, Hex Washer Head, 8-18 x 5/8
12A	1	18706	Yoke, Plastic, 1" NPT
		18706-02	Yoke, Plastic 3/4"
12B	1	13708	Yoke, 3/4"
	1	13708NP	Yoke, 3/4" Nickel Plated
	1	13398	Yoke, 1"
	1	13398NP	Yoke, 1" Nickel Plated
12C	1	19620	Yoke, 3/4", 90°, Plastic



# MODEL 5000

## By-Pass Valve Assembly, Brass

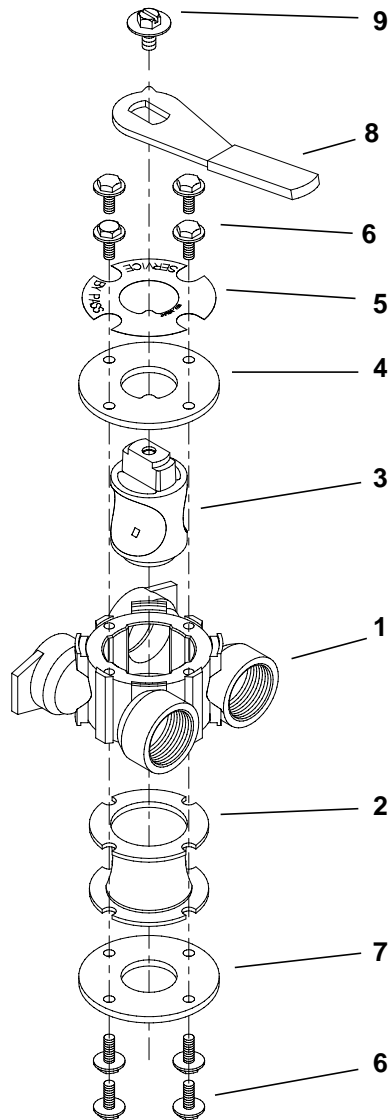

### Parts List

Item No.	Quantity	Part No.	Description
1.....	1	17290	By-Pass Valve Body, 3/4"
	1	17290NP	By-Pass Valve Body, 3/4" Nickel Plate
	1	13399	By-Pass Valve Body, 1"
	1	13399NP	By-Pass Valve Body, 1", Nickel Plate
2.....	1	11726	Seal, By-Pass
3.....	1	11972	Plug, By-Pass
4.....	1	11978	Side Cover
5.....	1	13604-01	Label
6.....	8	15727	Screw
7.....	1	11986	Side Cover
8.....	1	11979	Lever, By-Pass
9.....	1	11989	Screw, Hex Head, 1/4-14

# MODEL 5000SE Upflow

## Valve Wiring Diagram

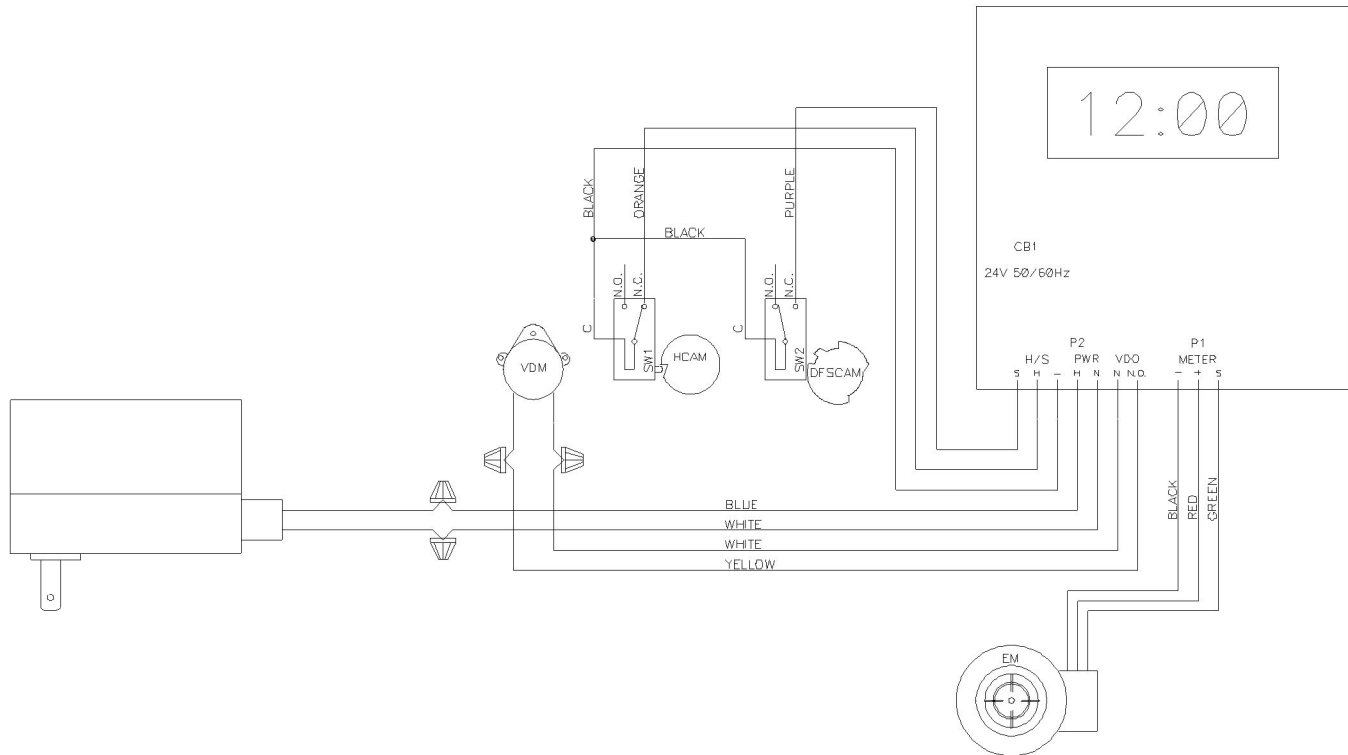

- CB1 - 5000SE Circuit Board
- VDM - Valve Drive Motor
- EM - Electronic Flow Meter (Optional)
- SW1 - Homing Switch
- SW2 - Step Switch
- HCAM - Homing Cam
- DFSCAM - Downflow Step Cam

# MODEL 5000SE Upflow

## Service Instructions

---

### A. TO REPLACE BRINE VALVE, INJECTORS, AND SCREEN

1. Turn off water supply to conditioner:
  - a. If the conditioner installation has a “three valve” by-pass system, first open the valve in the by-pass line, then close the valves at the conditioner inlet and outlet.
  - b. If the conditioner has an integral by-pass valve, put it in the by-pass position.
  - c. If there is only a shut-off valve near the conditioner inlet, close it.
2. Relieve water pressure in the conditioner by stepping the control into the backwash position momentarily. Return the control to the service position.
3. Unplug electrical cord from outlet.
4. Disconnect brine tube and drain line connections at the injector body.
5. Remove the two injector body mounting screws. The injector and brine module can now be removed from the control valve. Remove and discard brine body O-rings.
- 6A. To replace brine valve.
  1. Pull brine valve from injector body, also remove and discard O-ring at bottom of brine valve hole.
  2. Apply silicone lubricant to new O-ring and reinstall at bottom of brine valve hole.
  3. Apply silicone lubricant to O-ring on new valve assembly and press into brine valve hole, shoulder on bushing should be flush with injector body.
- 6B. To replace injectors and screen.
  1. Remove injector cap and screen, discard O-ring. Unscrew injector nozzle and throat from injector body.
  2. Screw in new injector throat and nozzle, be sure they are sealed tightly. Install a new screen.
  3. Apply silicone lubricant to new O-ring and install around oval extension on injector cap.
7. Apply silicone lubricant to three new O-rings and install over three bosses on injector body.
8. Insert screws thru injector cap and injector. Place this assembly thru hole in timer housing and into mating holes in the valve body. Tighten screws.
9. Reconnect brine tube and drain line.
10. Return by-pass or inlet valving to normal service position. Water pressure should now be applied to the conditioner, and any by-pass line shut off.

11. Check for leaks at all seal areas. Check drain seal with the control in the backwash position.
12. Plug electrical cord into outlet.
13. Set time of day and cycle the control valve manually to assure proper function. Make sure control valve is returned to the service position.
14. Make sure there is enough salt in the brine tank.
15. Start regeneration cycle manually if water is hard.

### B. TO REPLACE TIMER

1. Follow Steps A.1 through A.3.
2. Remove the control valve back cover. Remove the control valve front cover. Disconnect the meter dome signal wire from the front cover and feed it back through the control.
3. Remove screw and washer at drive yoke. Remove timer mounting screws. The entire timer assembly will now lift off easily.
4. Put new timer on top of valve. Be sure drive pin on main gear engages slot in drive yoke.
5. Replace timer mounting screws. Replace screw and washer at drive yoke. Replace meter signal wire.
6. Return by-pass or inlet valving to normal service position. Water pressure should now be applied to the conditioner, and any by-pass line shut off.
7. Replace the control valve back cover.
8. Follow Steps A.12 through A.15.

### C. TO REPLACE PISTON ASSEMBLY

1. Follow Steps A.1 through A.3.
2. Remove the control valve back cover. Remove the control valve front cover. Disconnect the meter dome signal wire from the front cover and feed it back through the control.
3. Remove screw and washer at drive yoke. Remove timer mounting screws. The entire timer assembly will now lift off easily. Remove end plug retainer plate.
4. Pull upward on end of piston yoke until assembly is out of valve.
5. Inspect the inside of the valve to make sure that all spacers and seals are in place, and that there is no foreign matter that would interfere with the valve operation.
6. Take new piston assembly as furnished and push piston into valve by means of the end plug. Twist yoke carefully in a clockwise direction to properly align it with drive gear. Replace end plug retainer plate.
7. Place timer on top of valve. Be sure drive pin on main gear engages slot in drive yoke.

# MODEL 5000SE Upflow

---

## Service Instructions (Cont'd.)

---

8. Replace timer mounting screws. Replace screw and washer at drive yoke.
9. Return by-pass or inlet valving to normal service position. Water pressure should now be applied to the conditioner, and any by-pass line shut off.
10. Replace the control valve back cover.
11. Follow Steps A.12 through A.15.

### D. TO REPLACE SEALS AND SPACERS

1. Follow Steps A.1 through A.3.
2. Remove the control valve back cover. Remove the control valve front cover. Disconnect the meter dome signal wire from the front cover and feed it back through the control.
3. Remove screw and washer at drive yoke. Remove timer mounting screws. The entire timer assembly will now lift off easily. Remove end plug retainer plate.
4. Pull upward on end of piston rod yoke until assembly is out of valve. Remove and replace seals and spacers.
5. Take piston assembly and push piston into valve by means of the end plug. Twist yoke carefully in a clockwise direction to properly align it with drive gear. Replace end plug retainer plate.
6. Place timer on top of valve. Be sure drive pin on main gear engages slot in drive yoke.
7. Replace timer mounting screws. Replace screw and washer at drive yoke.
8. Return by-pass or inlet valving to normal service position. Water pressure should now be applied to the conditioner, and any by-pass line shut off.
9. Replace the control valve back cover.
10. Follow Steps A.12 through A.15.

### E. TO REPLACE METER

1. Follow Steps A.1 through A.3.
2. Remove two screws and clips at by-pass valve or yoke. Pull resin tank away from plumbing connections.
3. Pull meter module out of control valve.
4. Remove signal wire from meter module, (snap tab on end opposite wire cable).
5. Apply silicone lubricant to four new O-rings and assemble to four ports on new meter module.
6. Install signal wire into new meter module.
7. Assemble meter to control valve. Note, meter portion of module must be assembled at valve outlet.
8. Push resin tank back to the plumbing connections and engage meter ports with by-pass valve or yoke.
9. Attach two clips and screws at by-pass valve or yoke. Be sure clip legs are firmly engaged with lugs.
10. Return by-pass or inlet valving to normal service position. Water pressure should now be applied to the conditioner, and any by-pass line shut off.
11. Check for leaks at all seal areas.
12. Follow Steps A.12 through A.15.

# MODEL 5000SE Upflow

## Troubleshooting Guide

SYMPTOM	PROBABLE CAUSE	CORRECTION
1. Softener fails to regenerate automatically.	A. Cord plugged into intermittent or dead power source. B. Disconnected meter cable. C. Defective power cord. D. Defective timer, meter or sensor.	A. Connect to constant power source. B. Reconnect cable. C. Replace cord. D. Replace or repair
2. Regeneration at wrong time.	A. Timer improperly set, due to Power failure.	A. Reset timer.
3. Loss of capacity.	A. Increased raw water hardness. B. Brine concentration and/or quantity. C. Resin fouling. D. Poor distribution, Channeling (uneven bed surface). E. Internal valve leak. F. Resin age. G. Resin Loss.	A. Reset unit to the new capacity. B. Keep brine tank full of salt at all times. Clean it yearly. Salt may be bridged. If using a salt grid plate ensure refill water is over it. C. Call dealer, find out how to confirm it, clean the resin and prevent future fouling. D. Call dealer. Check distributors and backwash flow. E. Call dealer. Replace spacers, seals and/or piston. F. Call dealer. Check for resin oxidation caused by Chlorine. Mushy resin. G. Call dealer. Check for correct bed depth. Broken distributors. Air or gas in bed: Well gas eliminator Loose brine line.
4. Poor water quality.	A. Check items listed in #3. B. Bypass valve open. C. Channeling.	B. Close by-pass valve. C. Check for too slow or high service flow. Check for media fouling.
5. High salt usage.	A. High salt setting. B. Excessive water in brine tank.	A. Adjust salt setting. B. See symptom No. 7.

# MODEL 5000SE Upflow

## Troubleshooting Guide (Cont'd.)

SYMPTOMS	PROBABLE CAUSE	CORRECTION
6. Loss of water pressure.	A. Scaling/Fouling of inlet pipe.	A. Clean or replace pipeline. Pretreat to prevent.
	B. Fouled resin.	B. Clean the resin. Pretreat to prevent.
	C. Improper backwash.	C. Too many resin fines and/or sediment. Call dealer, reset backwash flow rate, and/or adjust time.
7. Excessive water in brine tank and/or salty water to service.	A. Plugged Drain Line.	A. Check flow to drain. Clean flow control.
	B. Dirty or damaged brine valve.	B. Clean or replace brine valve.
	C. Plugged injector.	C. Clean injector and replace screen.
	D. Low inlet pressure.	D. Increase pressure to allow injector to perform properly (20 psig minimum.)
	E. Timer not cycling.	E. Replace timer.
8. Softener fails to use salt.	A. Plugged/restricted drain line.	A. Clean drain line and / or flow control.
	B. Injector is plugged.	B. Clean or replace injector and screen.
	C. No water in brine tank.	C. Check for restriction in BLFC. Ensure safety float is not stuck.
	D. Water pressure is too low.	D. Line pressure must be at least 20 psi.
	E. Brine line injects air during brine draw.	E. Check brine line for air leaks.
	F. Internal control leak.	F. Call dealer. Check piston, seals and spacers for scratches and dents.
9. Control cycles continuously.	A. Faulty timer.	A. Replace timer.
10. Continuous flow to drain.	A. Foreign material in control.	A. Call dealer. Clean valve, rebuild unit.
	B. Internal control leak.	B. Same as above
	C. Valve jammed in brine or backwash position.	C. Same as above
	D. Timer motor stopped or jammed.	D. Replace timer motor.

# MODEL 5000

## Service Assemblies

### AIR CHECK)

60002 Residential Type, #500

### BRINE LINE FLOW CONTROLS (BLFC)

60022-12 Model 1600 with .125 GPM Flow Control  
60022-25 Model 1600 with .25 GPM Flow Control  
60022-50 Model 1600 with .50 GPM Flow Control  
60022-00 Model 1600 with 1.00 GPM Flow Control

### BRINE VALVE

60032 Brine Valve Assembly

### COLLECTORS, UPPER

18280 1" Standard Slot (.010 - .012 slot size)  
18280-01 1" Wide Slot (.019 - .022 slot size)  
18280-02 1" Narrow Slot (.007 - .009 slot size)

### COVER

18260-00 Smoked Cover

### DISTRIBUTORS

60795 -00 1" x 72" Standard Slot  
(.010 - .012 slot size)  
60795-01 1" x 72" Wide Slot (.019 - .022 slot size)  
60795-02 1" x 72" Narrow Slot  
(.007 - .009 slot size)

### DRAIN LINE FLOW CONTROLS

60700-XX Drain Line Flow Control (8 - 15 gpm)  
60705-XX Drain Line Flow Control  
(From .6 - 7.0 gpm)  
60706-XX Drain Line Flow Control w/Quick  
Connect (From 8 - 15 gpm)

### FLOATS

60068 2310 Float

### FLOW CONTROL WASHERS

Brine Line Flow Controls  
17307 .125 GPM  
12094 .25 GPM  
10759 .50 GPM  
12097 1.00 GPM

### SERVICE EQUIPMENT

12664 1/4" Nut Driver  
12736 Stuffer Tool (Seals & Spacers)  
12874 Seal Hook  
13061 Puller Tool (Seals & Spacers)  
16908 Phillips Bit Large, 1/4" Drive  
16909 5/16" Magnetic Socket, 1/4" Drive  
16174 Silicone Grease, 2 oz. Tube  
16586-8 Silicone Grease, 8 lb. Pail  
40157 Wrench, Plastic By-Pass  
60135-5000SE Service Repair Kit

### TIMER

60652-01 Timer, 5000SE, Upflow

### YOKES

13708 3/4" NPT  
13708-10 3/4" BSP  
13708NP 3/4" NPT, Nickel Plated  
13708-10NP 3/4" BSP, Nickel Plated  
13708-45 3/4" Sweat  
13708-45NP 3/4" Sweat, Nickel Plated  
13708-40 1" Sweat  
13708-40NP 1" Sweat, Nickel Plated  
13398 1" NPT  
13398-10 1" BSP  
13398NP 1" NPT, Nickel Plated  
13398-10NP 1" BSP, Nickel Plated  
18706 1" Plastic, MNPT  
18706-10 1" Plastic, MBSP  
18706-02 3/4" Plastic, MNPT  
18706-12 3/4" Plastic, MBSP  
19275 3/4" 90° Angle, NPT  
19275-10 3/4" 90° Angle, BSP  
19275NP 3/4" 90° Angle, NPT, Nickel Plated  
19275-10NP 3/4" 90° Angle, BSP, Nickel Plated  
19275-45 3/4" 90° Angle Sweat  
19275-45NP 3/4" 90° Angle Sweat, Nickel Plated  
19620-01 90° Adapter Coupling

### DRAIN LINE FLOW CONTROLS

19153 .06 GPM  
19152 .08 GPM  
19151 1.0 GPM  
12085 1.2 GPM  
19150 1.3 GPM  
12086 1.5 GPM  
19149 1.7 GPM  
12087 2.0 GPM  
12088 2.4 GPM  
12089 3.0 GPM  
12090 3.5 GPM  
12091 4.0 GPM  
19147 4.5 GPM  
12092 5.0 GPM  
17814 6.0 GPM  
12408 7.0 GPM  
17943 8.0 GPM  
17944 9.0 GPM  
16529 10 GPM  
16735 12 GPM  
16736 15 GPM

# MODEL 5000

---

## *Service Assemblies (Cont'd.)*

---

### **INJECTORS (1610)**

18272-000	#000 Brown Injector
18272-00	#00 Violet Injector
18272-0	#0 Red Injector
18272-1	#1 White Injector
18272-2	#2 Blue Injector

### **METER MODULE**

60626	3/4" Turbine Meter
-------	--------------------

### **PISTON**

60115-10	Piston Assembly, Upflow
----------	-------------------------

### **POWER HEAD**

60201-011	Powerhead, Upflow
-----------	-------------------

### **SAFETY BRINE VALVE**

60014	2310 Plastic
-------	--------------

### **SALES & SERVICE AIDS**

40311	Spec Sheet
40312	Service Manual
16700	Product Line Brochure

### **SEALS & SPACERS**

60120	Seal and Spacer Kit
-------	---------------------



# MODEL 5000

## Flow Data, Injector Draw & Slow Rinse Rates

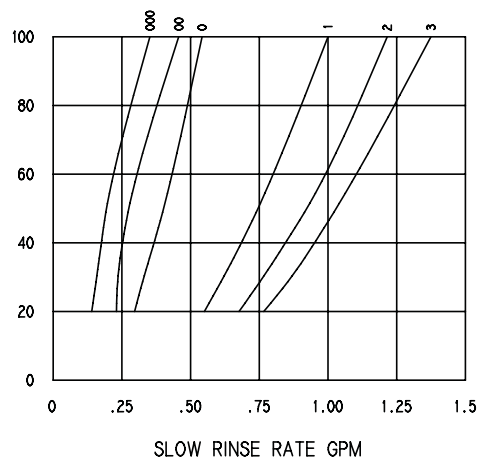
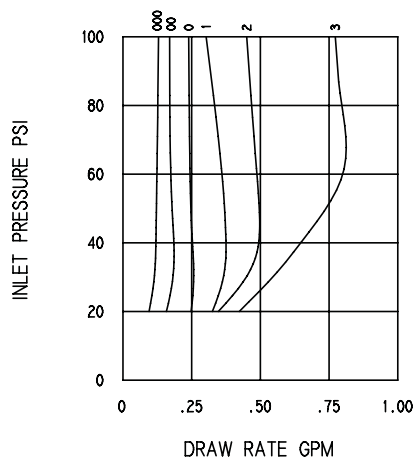
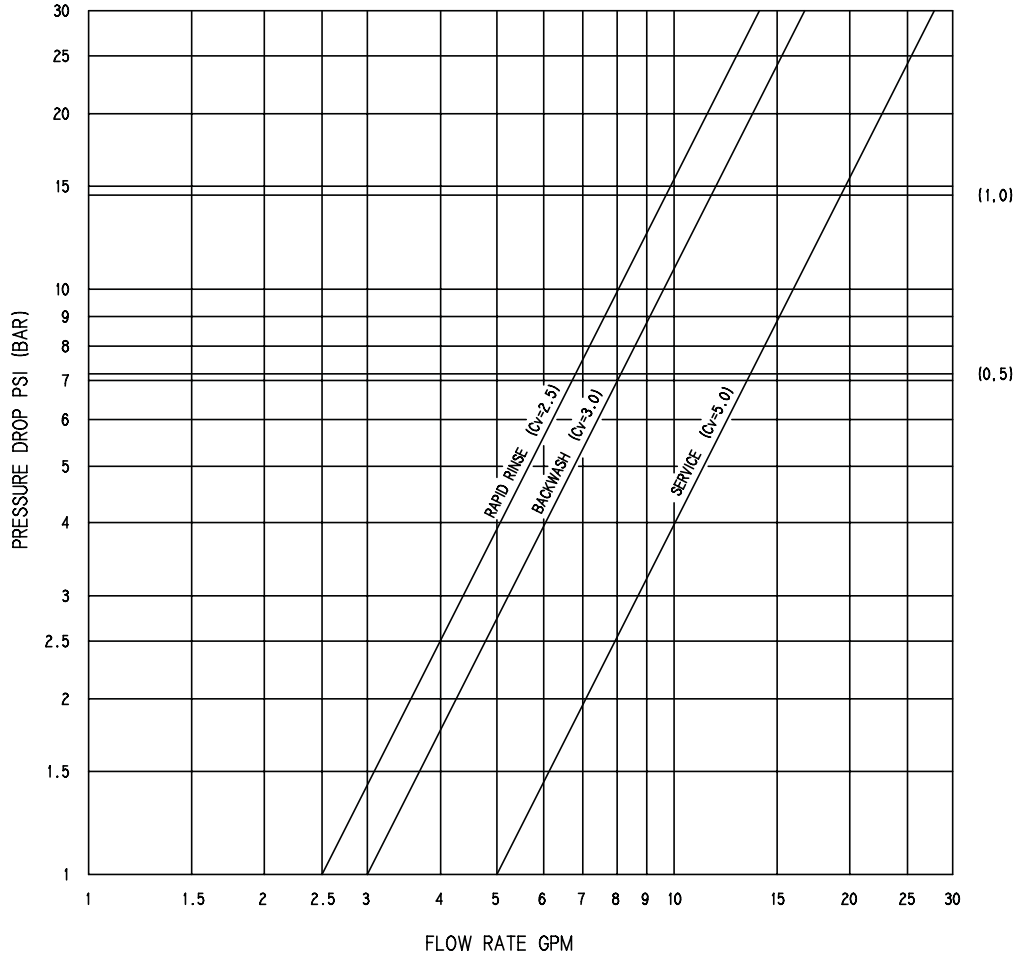

---

*Notes*

---

---

*Notes*

---

