

# Series 962

Electronic Stager Control

## Operation Manual

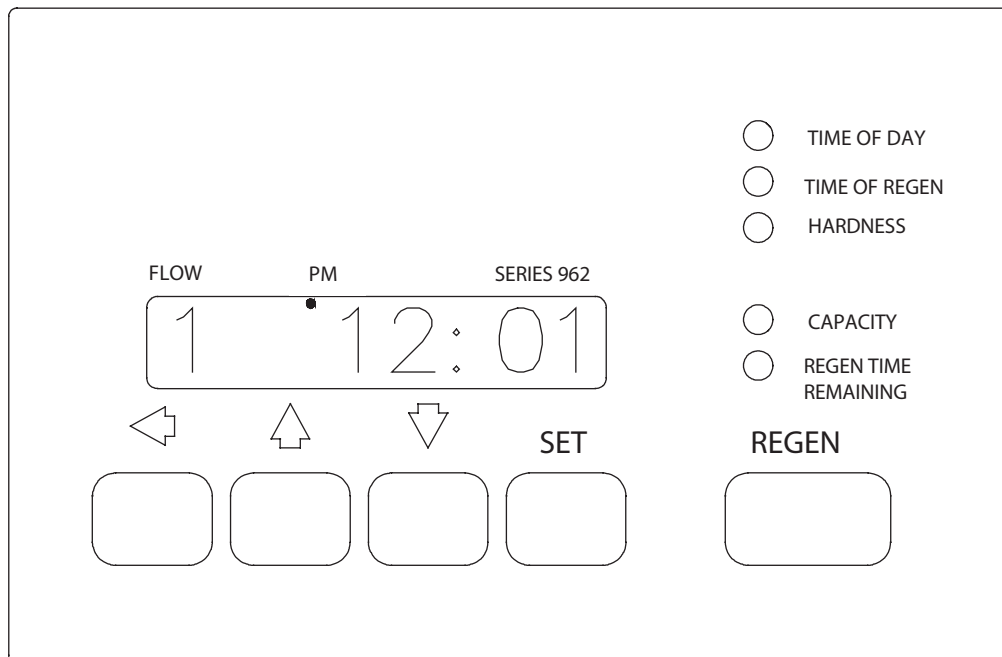



---

# **Table of Contents**

---

Declaration of Conformity . . . . .	3
Caution and Warning Symbols . . . . .	4
Series 962 Electronic Stager Controls . . . . .	6
Special Features of the Series 962 Stagers. . .	6
Memory Retention	
Programmable Cycles	
Double Regeneration	
Capacity Setting Lockout	
Selectable Reserve Options	
U.S. or Metric Units of Measure	
Calendar Override	
Manual Regeneration	
Operating Histories	
Remote Regeneration	
Selectable Automatic Regeneration	
Optional Battery Backup	
Flow Rate Display	
Programming the Series 962 Stager . . . . .	7
Factory Default Values	
Program Levels	
Level I Programming	
Setting Time of Day	
Level II Programming	
Changing a Program Value	
Level III Programming	
Level IV Programming	
Entering “C” Values	
Entering “d” Values	
Viewing a Program Value	
Manual Regeneration	
Lock-out Feature	
Flow Sensor Select Options . . . . .	9
Capacity Based Regeneration Start Options . .	9
Immediate Regeneration Only Option	
Installation Programmed Values Chart	
Advance Cycle Function . . . . .	7
Cancel Regeneration Function . . . . .	7
Parallel Operation . . . . .	15
Twin Alternating Operation . . . . .	15
Flow Sensor Connections . . . . .	16
AC Power Wiring . . . . .	16
Remote Regeneration . . . . .	17
Relay Output Option . . . . .	17

# Caution and Warning Symbols

The following international symbols appear in this manual to highlight caution and warning messages.

## Cautions

Not heeding these messages could result in personal injury and/or damage to equipment.



**Caution:** This symbol indicates caution messages (Refer to User Manual).

## Warnings

Not heeding these messages could result in serious personal injury.



**Warning:** This symbol is intended to alert the user to the presence of “dangerous voltage” within the product’s enclosure that may be of sufficient magnitude to constitute a risk of electric shock to persons.

## Specifications



**Warning: Class I equipment** - The composite enclosure used in this equipment does not automatically provide grounding between conduit connections. Use grounding bushing and jumper wires as part of the installation. **To avoid electric shock, grounding must be installed by the customer as part of the installation. Installation should be completed by qualified electricians and in accordance with the requirements of all state and local electrical codes as well as the National Electrical Code (NEC). A separate ground post has been provided inside this equipment enclosure and is indicated by the NEC ground symbol as shown below.**



NEC Ground Symbol



**Warning: Overcurrent Protection** - This equipment is not supplied with built in overcurrent protection (fuses or circuit breakers). An external switch and/or circuit breaker must be installed by a qualified electrician in accordance with all state and local electrical codes as well as the National Electrical Code (NEC). The external switch and/or

circuit breaker must be in close proximity to this equipment and in easy reach of the operator. It must be clearly marked to indicate that it is the disconnecting device for this equipment. Recommend fuse size is 1 AMP.

**Voltage Range:** 230/115VAC (+/- 10%)

**Frequency Range:** 50/60Hz

**Max. Rated Power:** 4 Watts

**Pollution Degree:** 2

**Overvoltage Category:** II

**Altitude:** 6500 Ft. (2000 Meters)

**Max. Rated Fluid (Air/Water) Pressures**

Model E948	Model E951	Model E958/ E959
125 psi (8.6 bar)	125 psi (8.6 bar)	125 psi (8.6 bar)

**NEMA 4X Enclosure:** Intended for indoor or outdoor use primarily to provide a degree of protection against corrosion, windblown dust and rain, splashing water; undamaged by the formation of ice on the enclosure. The enclosure door must be kept tightly closed using all fasteners provided. **Any modifications to this enclosure (i.e., added holes for cable entry/mounting, conduit connections...etc.) may void the intended NEMA 4X rating. NEMA 4 and UL rated fittings should be used when modifying the enclosure.**

**Relative Humidity Operating Range:**

Temperature Range	Allowed Relative Humidity
0°C to 37°C (32°F to 99°F)	10% to 100% Condensing
38°C to 55°C (100°F to 131°F)	10% to 75% Non-Condensing

## **Inputs**

### **Terminal Strip 1 (TB1) High Voltage**

TB1, Terminal #1: Line Voltage Input

TB1, Terminal #4: Neutral Input

TB1, Terminal #6: Input to Aux. Switch Common

### **Optional Relay Inputs**

Relay Terminal #6: Relay Common Input

### **Terminal Strip 2 (TB2) Low Voltage**

TB2, Terminal #11: Turbine Meter Ground Input

TB2, Terminal #12: Turbine Meter Shield Input

TB2, Terminal #13: Turbine Meter Signal Input

TB2, Terminal #17: Delayed Start Input (Dry Contact)

TB2, Terminal #18: Delayed Start Input (Dry Contact)

TB2, Terminal #19: Lockout Input (Dry Contact)

TB2, Terminal #20: Lockout Input (Dry Contact)

## **Outputs**

### **Terminal Strip 1 (TB1) High Voltage**

TB1, Terminal #7: Aux. Switch N.C. Output

TB1, Terminal #8: Aux. Switch N.O. Output

### **Optional Relay Outputs**

Relay Terminal #2: Relay N.C. Output

Relay Terminal #3: Relay N.O. Output

### **Terminal Strip 2 (TB2) Low Voltage**

TB2, Terminal #14: Turbine Meter +12VDC Output

TB2, Terminal #12: Turbine Meter Shield Input

TB2, Terminal #13: Turbine Meter Signal Input

---

# Series 962 Electronic Stager Controls

---

The Series 962 Electronic Stager Controls provide sophisticated, demand-based water conditioning by combining a microprocessor with a flow meter to electronically monitor the amount of water used. This fully programmable series of controls provide the ability to fine tune the operation to meet the application requirements. There are several 962 Stager models available.

Single Unit Controls	Model No.
Basic Softeners & Filters	E948
Complex Softeners & Filters	E951

Multiple Unit Controls	Model No.
Twin Alternating Softeners & Filters	E958-TA E958-TB
Sequential Filters (Backwash Only)	E948
2 Unit Sequential Filters	E951
3 or 4 Unit Sequential Filters	E958

## Special Features of the Series 962 Control

### Memory Retention

During a power outage, critical operating information is stored in nonvolatile memory. This information includes the time of day, water usage, all programming data and the number of days since the last regeneration. When power is restored, the information is returned to the microprocessor and operation resumes as if an outage never occurred. The time of day will be late by the length of the power outage. The time of day should be reset after an extended power outage. No other reprogramming is necessary. An optional backup battery will allow the control to keep track of time and water usage for up to 8 hours during a power outage. **The control will not initiate a regeneration while on battery backup.**

### Programmable Cycles

The control is flexible in defining the appropriate cycles of operation.

### Double Regeneration

For single tank applications, the control automatically calls for a second regeneration the following day if the current operation cycle exceeds the programmed capacity by 150% or more.

### Capacity Setting Lockout

The control can be programmed to lock the capacity so it cannot be altered after installation.

### Selectable Reserve Options

To meet the application requirements, the control allows selection of one of two reserve types:

**Fixed Reserve** - The reserve is fixed at a programmable percentage (30% factory preset) of the total capacity.

**Variable Reserve** - The controller monitors the daily water usage and at the programmed time of regeneration, calculates the average water used for each day of the week. The reserve capacity is set to 120% of the average water usage for the next day.

### U.S. or Metric Units of Measure

To meet your display and programming requirements, the 962 Stager uses grains per gallon of hardness and kilograins of capacity for U.S. units; or parts per million of hardness and kilograms of capacity as gallons or cubic meters.

### Calendar Override

If the volume of water used has not caused a regeneration, the 962 Stager can be set to regenerate every one to thirty days.

### Manual Regeneration

A separate **REGEN** button is provided for manual regenerations. A double manual regeneration feature is included that allows back-to-back regenerations.

### Operating Histories

Important operating data is stored in memory and is retrievable upon demand.

The historical data includes peak flow data as well as average daily water usage for each day of the week.

## Remote Regeneration

A set of input terminals with a programmable delay are provided as a standard feature of the 962 Stager that allows regeneration to be initiated from a remote location. This feature can be used to facilitate remote manual regeneration requirements or assist in further automating the control system such as the use of a differential pressure switch.

## Selectable Automatic Regenerations

There are four automatic regeneration methods; “delayed with immediate override”, “delayed only”, “day of week”, and “calendar override”. Immediate regeneration is used to start an automatic regeneration immediately when the capacity remaining in a tank is reduced to zero. Delayed regeneration is used to start an automatic regeneration at a predetermined time of day when the capacity remaining is below a defined reserve. The reserve capacity may be fixed or variable. The variable reserve is determined by past usage history. Regeneration can be accomplished based on the day of the week at a specific time of day or after programmable number of days since the last regeneration.

## Optional Battery Backup

An optional backup battery can be provided so that the Time of Day and water usage will be maintained for up to **8 hours** during a power outage. All 962 Stager controls are provided as “Battery Backup Capable”. If the optional battery backup is provided with the Series 962, make sure that it is properly connected.

### BATTERY BACKUP CONNECTIONS

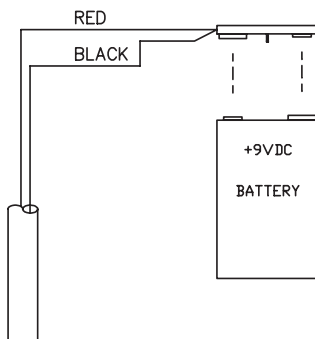

Figure 1

## Flow Rate Display

In the normal operating mode the series 962 Stager control will alternate between **Capacity Remaining** (gallons or m<sup>3</sup>) and **Flow Rate** (gallons per minute or m<sup>3</sup>/hr). In the event of power loss, (including battery power) the display will alternate between **Time of Day** and **Capacity Remaining** once power has been restored. The control will remain in this display mode until the Time of Day is reset or until any button is pressed. The flow rate display is indicated by a small L.E.D. in the top left corner of the display. When P19 is set to “4” (user defined pulse equivalent) flow rate will not be displayed.

## Programming the Series 962 Stager Control

This section contains common aspects of programming the 962 control and retrieving historical operating data. A label provided with the control should be filled out with programming parameters on system start-up.

## Factory Default Values

Factory default values are shown on Table 1. **Capacity and Hardness values are set to 0 and must be changed to appropriate values before the control will operate. “Err 4” will be displayed until a valid number is entered for each of these items.**

## Program Levels

The Series 962 Stager controls have been designed to facilitate different levels of programming requirements. Level I includes program variables that are frequently referenced by users, operators, installers and service personnel. They are accessible without the requirement of codes. Level II includes variables that are most typically used at the time of installation and initial setup. They are accessible only with access codes. Level III locations are used primarily for accessing operation history information. Level IV locations are used to set the regeneration days of the week. Level III and IV parameters also require access codes. Programming levels are further defined in Tables I, II, and III.

Levels	Access Code
I	None Required
II	Press and hold the (↑) and (↓) arrow buttons for 3 seconds
III	Press and hold the (←) and (↑) arrow buttons for 3 seconds
IV	Press and hold the (←) and (↓) arrow buttons for 3 seconds

## Level I Programming

Level I program values are identified by the legend on the faceplate of the control. A green LED is illuminated when a Level I "P" value is displayed. Following are the Level I "P" values:

- Time of Day P1
- Time of Regeneration P2
- Hardness P3
- Capacity P5

**P4 is skipped on the 962 Stager Programming.**

### Setting Time of Day

Press the **SET** button. The display will show the time of day with the minutes digit blinking. Press the UP (↑) arrow button to increase the number or the DOWN (↓) arrow button to decrease the number. To skip the number without changing, press the LEFT (←) arrow button. The first digit will stop flashing and the next digit will start flashing. When the far left digit is reached, pressing the LEFT (←) arrow button returns the flashing to the far right digit. Continue changing numbers until the desired Time of Day is obtained. Press the **SET** button to enter the value. The PM indicator will toggle when the "tens digit" of the hours is increased. The far left digit is used to indicate the day of week. Number 1 being Sunday and number 7 being Saturday.

The time of Regeneration, Hardness, and Capacity are set in a similar manner.

## Level II Programming

The control will automatically enter Level II programming if P19 or P20 have not been set.

Press and hold the (↑) and (↓) arrow buttons for 3 seconds to enter the Level II programming mode. The display will show the letter "P" in the far left display digit. The parameter "P-number" is displayed in the far right display digit. See Table 1 for Level I and II programming values.

### Changing a Program Value

Once the P value you want to change is displayed, press the (←) arrow button to display the current entry for that value. To change or modify the value, press the **SET** button. The digit on the right hand side of the display will begin to flash. Use the (↑) or (↓) arrow buttons to select the desired entry. Once the desired entry is obtained, press the (←) button to move to the next digit and change as needed. Once you have completed the appropriate changes, press the **SET** button. When you press the **SET** button the new entry is stored and the control automatically scrolls to the next P value. If a beep sounds, the new entry was not accepted. Table 1 lists the range available for a specific program value.

## Level III Programming

Press and hold the (←) and (↑) arrow buttons for 3 seconds to enter the Level III programming mode. The display will show the letter "L" in the far left display digit. The parameter "L-number" is displayed in the far right display digit. The **SET** button is inactive except for L4. If **SET** is pressed when L4 is displayed, Peak Flow is reset to zero. If **SET** is pressed when any other location is displayed the control will beep.

## Level IV Programming

Press and hold the (←) and (↓) arrow buttons for 3 seconds to enter the Level IV programming mode. Level IV programming is used to enter the user defined cycle times and day of week regeneration. All controllers have default settings for 4 cycle softener operation. **The operation type is determined by the value that is programmed in "P17" and must be changed if not being used as a 4 cycle conditioner.**

### Entering "C" Values

"C" values are used to define a specific number of cycles to meet the application needs and are accessible through level IV programming mode.

**Example:** If the control is used in a system that has a total of 10 cycles of operation, select 6 for P17 and program C1-C10 for the amount of time desired for each cycle (up to 255 minutes).

Each "C" value represents 1 position of the rotary pilot stager that is being used. A maximum of 15 cycles may be used, each programmable from 0-255 minutes.

While the controller is in regeneration the display will show a "C" value in the far left display and the time remaining (in minutes) for that "C" value.

**Example:** [C1 15] = 15 min remaining in C1.

### Entering "d" Values (Regeneration Days)

"d" values are used to start a regeneration on a certain day of the week. There are seven "d" values numbered from 1 to 7, with 1 representing Sunday and 7 representing Saturday. Set a 1 in "d7" to initiate an automatic regeneration every Saturday at the Time of Regeneration (P2). The automatic regenerations will occur at the time set in P2 regardless of the capacity remaining in the system. A value of "0" indicates no regeneration on that day. The default value is "0" for all "d" values.



## Viewing a Program Value

Programmed values may be viewed at any time. Program values may not be changed during a regeneration.

**Level I** - To locate and display a P value in Level I press the (↑) or (↓) arrow button until the desired value is displayed. Level I parameters are indicated by the legend on the face plate of the control.

**Level II** - To locate and display a P value in Level II, simultaneously press the (↑) and (↓) arrow buttons for 3 seconds to gain access. Press the (↑) or (↓) arrow buttons until the desired location is displayed. Press (←) to display the value in the P location.

**Level III** - To locate and display an L value in Level III, simultaneously press the (←) and (↑) arrow buttons for 3 seconds to gain access and then press the (↑) or (↓) arrow buttons until the desired location is displayed. Press (←) to display the value in the L location.

**Level IV** - To locate and display a “d” value in Level IV, simultaneously press the (←) and (↓) arrow buttons for 3 seconds to gain access and then press the (↑) or (↓) arrow buttons until the desired location is displayed. Press (←) to display the value in the “d” location.

## Manual Regeneration

To initiate a manual regeneration, simply press and hold the **REGEN** button for 3 seconds. If an immediate second regeneration is desired, wait for at least **one minute** after the first regeneration begins and then press and hold the **REGEN** button for 3 seconds. A second regeneration will be performed immediately following the first. The display will freeze and only show the Regeneration Time Remaining as an indication that the second regeneration will be initiated. When the first regeneration is complete, the second regeneration will begin and the display will alternate between Flow Rate and Regeneration Time Remaining. The second regeneration will be performed on the offline tank in twin alternating applications.

## Lock-Out Feature

The lock-out feature may also be used to prevent regenerations when a signal is present at the lock-out terminals. Two or more 962 controls can be connected together (see Figure 2) to prevent one from regenerating while another is in regeneration. This signal can also come from external equipment that can provide a dry contact closure. (CONNECTION MUST BE A DRY CONTACT).

**NOTE:** When using the Relay Output Option the lockout feature cannot be used.

## Flow Sensor Select Options

P19 is used to select the flow sensor type. Numbers 1 and 2 are for the Autotrol 1 inch and 2 inch turbine type flow sensors. The number in P20 will be ignored when P19 is programmed with a 1 or 2.

Other flow sensors can be used by entering a “3” in P19 and entering the correct “K-factor” in P20. The K-factor is defined as pulses per gallon for U.S. units or pulses per liter for metric units. The K-factor can be obtained from the flow sensor manufacturer.

If a “4” is entered in P19 then the definition of the number in P20 becomes gallons or liters per pulse depending on the units of measure selected.

## Capacity Based Regeneration Start Options

The following is an explanation of the regeneration start options for single tank 962 Stager controls.

At the time of regeneration (time set in P2) the control will check to see if a regeneration should start. This check depends on the value programmed in P15.

### P15 = 0 or 2 Variable Reserve

The control calculates an average water usage for each day of the week when it is using variable reserve. A regeneration will start if the capacity remaining is less than 1.2 times the average water usage for the next day.

### P15 = 1 or 3 Fixed Reserve

The reserve capacity is calculated using the fixed reserve capacity programmed in P16. The value in P16 is the percentage of the calculated system capacity used for the reserve.

**Example:** If the programmed capacity is 10,000 grains and the hardness is 10 grains/gallon the calculated system capacity is 1000 gallons. The reserve capacity is 300 gallons if the fixed reserve is set to 30%. A regeneration will start if the capacity remaining at the time of regeneration is less than 300 gallons.

The parameter P15 is also used to select immediate regenerations or delayed regenerations only.

### P15 = 0 or 1 Delayed Regeneration Only

Automatic regenerations will occur at the time of regeneration only. The control will delay the start of regeneration until the time of regeneration even if the capacity remaining is reduced to zero gallons.

## **P15 = 2 or 3 Immediate Regeneration Override**

In addition to delayed regenerations automatic regenerations will occur at any time during the day if the capacity remaining reaches zero.

### **Immediate Regeneration Only Option**

Automatic regenerations performed at the time of regeneration (P2) can be eliminated by setting the control for fixed reserve with immediate regeneration override (P15 = 3) and setting the reserve capacity percentage (P16) to 0%. This will create a reserve capacity of zero gallons and override the Time of Regeneration (P2) to allow for an immediate regeneration. **These are the preferred settings for a Twin Alternating softener system.**

### **Advance Cycle Function**

While in a regeneration cycle, you can advance the stager to the next cycle by pressing and holding the left arrow key (←) for 3 seconds. The stager and controller will then advance to the next regeneration cycle.

### **Cancel Regeneration Function**

To cancel (abort) a regeneration, press and hold the left arrow (←) and **SET** keys for 3 seconds. The control will display an ERROR 3 and return the stager to the service (Home) position. Once in the service position, ERROR 3 will be cleared.

Press and hold the (↑) and (↓) arrow buttons to access Level II.

**Table 1 - Level I and II Parameters**

Parameter		Range of Values <sup>a</sup>	Minimum Increments	Default	Units of Measure	Notes
Name	Description					
P1	Day of week and time of day	(1-7) 1:00-12:59 AM or PM (1-7) 0:00 -23:59	(1 day) 1 minute	None	hour:minute	Range depends on value selected for P13. For day of week, SUN=1, MON=2, TUE=3, WED=4, THU=5, FRI=6, SAT=7
P2	Time of day to start regeneration	1:00-12:59 AM or PM 0:00-23:59	1 minute	2:00 am	hour:minute	Range depends on value selected for P13. Use only if P15 = 1
P3	Hardness of water	3-250 30-2500	1 10	0 0	grains/gallon ppm	Unit of measure depends value selected for P12
P4						Not Used
P5	Capacity of unit	1-5100 .1-510.0	1 .1	0	kilograins <sup>b</sup> kilograms <sup>b</sup>	Unit of measure depends on value selected for P12
P6						Not Used
P7						Not Used
P8						Not Used
P9	Backwash time	1-30	1	14	minutes	If P17=6 or 9, Do not program P9
P10	Rinse/Draw time	1-125	1	40	minutes	If P17=3, 6, or 9, Do not program P10
P11	Rinse time	1-19	1	4	minutes	If P17=6 or 9, Do not program P11
P12	Units of measure	0-1	1	0		0 = US, 1 = Metric
P13	Clock mode	0-1	1	0		0 = 12 hour clock 1 = 24 hour clock
P14	Calendar override	0-30	1	0	days	0 = no calendar override
P15	Reserve Type	0-3	1	0		0 = Variable reserve, 1 = fixed reserve, 2 = variable reserve with immediate regeneration, 3 = fixed reserve with immediate regen
P16	Initial average usage or fixed reserve	0-70	1	30	% of capacity	Description depends on value entered for P15
P17	Operation type <sup>c</sup>	3-9	1	4		0 - 2 = Not Used, 3 = 3 cycle filter 4 = 4 cycle softener, 5 = 4 cycle (180/182) butterfly config., 6 = User defined cycle times <sup>d</sup> , 9 = User defined (58-TB & 58-TR only). <sup>d</sup>
P18	Capacity change lock-out	0-1	1	0		0 = None, 1 = Capacity change locked-out
P19	Flow sensor select	1-4	1	3		1 = 1.0" Autotrol turbine, 2 = 2.0" Autotrol turbine, 3 = User defined K-factor (PPG), 4 = User defined pulse equivalent (GPP)
P20	K-factor or pulse equivalent	0.01-255.00	.01	0.01		Number used for meter K-factor or pulse equivalent
P21	Remote regeneration switch delay	1-254	1	60	seconds	Time remote switch must be active to start a regeneration

a. All parameters must be set within acceptable range of values or ERR4 will be displayed.

b. See Table 2 for conversions.

c. When using options 6 or 9 programming "C" values per Table 3 eliminates the need to program P9 through P11.

d. Program "C" values per Table 4.

**Table 2 Conversions**

To Convert Capacity in	Into Capacity in	Multiply by
kilograms (kg)	kilograins (kgr)	15.43
kilograins (kgr)	kilograms (kg)	0.0648
moles of CaCO <sub>3</sub>	kilograms (kg)	0.10
equivalents of CaCO <sub>3</sub>	kilograms (kg)	0.05

Press and hold the (←) and (↑) arrow buttons to access Level III.

**Table 3 Level III History Data**

Location	Range	Description
L 1	1-7	Day of week (Sun=1, Sat=7)
L 2	0-255	Days since last regeneration
L 3	1:00-12:59/0:00-23:59	Time that peak flow occurred
L4 <sup>a</sup>	0-200/0-50.0	Peak flow gallons per minute/cubic meters (M <sup>3</sup> ) per hour since location reset
L 5	0-655360/0-6553.6	Water used today in gallons/M <sup>3</sup> since time of regeneration
L 6	0-655360/0-6553.6	Water used since last regeneration in gallons/M <sup>3</sup>
L 7	0-655360/0-6553.6	Average water usage for Sunday in gallons/M <sup>3</sup>
L 8	0-655360/0-6553.6	Average water usage for Monday in gallons/M <sup>3</sup>
L 9	0-655360/0-6553.6	Average water usage for Tuesday in gallons/M <sup>3</sup>
L 10	0-655360/0-6553.6	Average water usage for Wednesday in gallons/M <sup>3</sup>
L 11	0-655360/0-6553.6	Average water usage for Thursday in gallons/M <sup>3</sup>
L 12	0-655360/0-6553.6	Average water usage for Friday in gallons/M <sup>3</sup>
L 13	0-655360/0-6553.6	Average water usage for Saturday in gallons/M <sup>3</sup>
L 14	0-999990/0-99999.9	Total water used since NOVRAM test in gallons/M <sup>3</sup> (LSD)
L 15	0-167/0-16	Total water used since NOVRAM test in gallons/M <sup>3</sup> x 10 <sup>6</sup> (MSD)

a. Press and hold SET for 5 seconds to reset.

Press and hold the (←) and (↓) arrow buttons to access Level IV.

**Table 4 Level IV Parameters**

#	Description of Parameter	Range of Values	Minimum Increment	Default	Notes
C1	Position 1 Cycle Time	0 min -255 min	1 min	0	Stager Cycle (P17=6 or 9)
C2	Position 2 Cycle Time	0 min -255 min	1 min	0	Stager Cycle (P17=6 or 9)
C3	Position 3 Cycle Time	0 min -255 min	1 min	0	Stager Cycle (P17=6 or 9)
C4	Position 4 Cycle Time	0 min -255 min	1 min	0	Stager Cycle (P17=6 or 9)
C5	Position 5 Cycle Time	0 min -255 min	1 min	0	Stager Cycle (P17=6 or 9)
C6	Position 6 Cycle Time	0 min -255 min	1 min	0	Stager Cycle (P17=6 or 9)
C7	Position 7 Cycle Time	0 min -255 min	1 min	0	Stager Cycle (P17=6 or 9)
C8	Position 8 Cycle Time	0 min -255 min	1 min	0	Stager Cycle (P17=6 or 9)
C9	Position 9 Cycle Time	0 min -255 min	1 min	0	Stager Cycle (P17=6 or 9)
C10	Position 10 Cycle Time	0 min -255 min	1 min	0	Stager Cycle (P17=6 or 9)
C11	Position 11 Cycle Time	0 min -255 min	1 min	0	Stager Cycle (P17=6 or 9)
C12	Position 12 Cycle Time	0 min -255 min	1 min	0	Stager Cycle (P17=6 or 9)
C13	Position 13 Cycle Time	0 min -255 min	1 min	0	Stager Cycle (P17=6 or 9)
C14	Position 14 Cycle Time	0 min -255 min	1 min	0	Stager Cycle (P17=6 or 9)
C15	Position 15 Cycle Time	0 min -255 min	1 min	0	Stager Cycle (P17=6 or 9)
d1	Sunday	0-1	1	0	0 = no day of week regen this day
d2	Monday	0-1	1	0	0 = no day of week regen this day
d3	Tuesday	0-1	1	0	0 = no day of week regen this day
d4	Wednesday	0-1	1	0	0 = no day of week regen this day
d5	Thursday	0-1	1	0	0 = no day of week regen this day
d6	Friday	0-1	1	0	0 = no day of week regen this day
d7	Saturday	0-1	1	0	0 = no day of week regen this day

Note: The number of “C” values MUST equal exactly the number of stager regeneration cycles.

Example: If the parameter “Position 5 Cycle Time” is programmed then C1 through C4 must also be programmed.

**Table 5 “C” Level Program Values for Select Stager Configurations**

#	48-83	51-09	51-10	51-86	58-00	58-03	58-04	58-TB
C1	BW1 Time	BW Time	BW1 Time	BW1 Time	BW1 Time	BW1 Time	BW1 Time	BW Time
C2	BW2 Time	BR/SR Time	FR1 Time	BW2 Time	Draw1 Time	FR1 Time	FR1 Time	Draw Time
C3	BW3 Time	FR Time	BW2 Time	BW3 Time	SR1 Time	BW2 Time	BW2 Time	SR Time
C4	0	Refill Time	FR2 Time	BW4 Time	FR1 Time	FR2 Time	FR2 Time	FR Time
C5	0	0	0	BW5 Time	BW2 Time	BW3 Time	BW3 Time	0
C6	0	0	0	BW6 Time	Draw2 Time	FR3 Time	FR3 Time	0
C7	0	0	0	0	Rinse2 Time	0	BW4 Time	0
C8	0	0	0	0	FR2 Time	0	FR4 Time	0
C9	0	0	0	0	0	0	0	0
C10	0	0	0	0	0	0	0	0
C11	0	0	0	0	0	0	0	0
C12	0	0	0	0	0	0	0	0
C13	0	0	0	0	0	0	0	0
C14	0	0	0	0	0	0	0	0
C15	0	0	0	0	0	0	0	0

**Table 6 Error Code Identification**

<b>Error Code</b>	<b>Description</b>
1	Data stored in NOVRAM has been corrupted and is incorrect
2	Home switch (SW 2) closed when it should be open
3	Home switch (SW 2) open when it should be closed
4	One or more parameters are below the minimum value in Table I
5	System capacity less than 10 gallons or 0.1 m <sup>3</sup> (Capacity is set too low or Hardness is set too high)

**Table 7 Installation Programmed Values Chart**

<b>Installation Date:</b>					
<b>“P” Value</b>	<b>Description</b>	<b>Install Values</b>	<b>“C”/”d” Value</b>	<b>Description</b>	<b>Install Values</b>
P1	Day of week/Time of day		C1	Position 1 Cycle Time	
P2	Time of regeneration		C2	Position 2 Cycle Time	
P3	Hardness of water		C3	Position 3 Cycle Time	
P4	Not used		C4	Position 4 Cycle Time	
P5	Capacity of unit		C5	Position 5 Cycle Time	
P6	Not used		C6	Position 6 Cycle Time	
P7	Not used		C7	Position 7 Cycle Time	
P8	Not used		C8	Position 8 Cycle Time	
P9	Backwash time		C9	Position 9 Cycle Time	
P10	Rinse/Draw time		C10	Position 10 Cycle Time	
P11	Purge time		C11	Position 11 Cycle Time	
P12	Units of measure		C12	Position 12 Cycle Time	
P13	Clock Mode		C13	Position 13 Cycle Time	
P14	Calendar override		C14	Position 14 Cycle Time	
P15	Reserve type		C15	Position 15 Cycle Time	
P16	Initial average value or fixed reserve capacity		d1	Regenerate on Sunday	
P17	Operation type		d2	Regenerate on Monday	
P18	Capacity change lock out		d3	Regenerate on Tuesday	
P19	Turbine select		d4	Regenerate on Wednesday	
P20	K-factor or pulse equivalent		d5	Regenerate on Thursday	
P21	Remote regeneration switch delay		d6	Regenerate on Friday	
P22	Factory use only. Do not program.		d7	Regenerate on Saturday	

## Parallel Operation

The 962 Stager control can be used for twin and triple tank applications, operating in a parallel mode. Parallel systems can be implemented with up to three individual controls by using the lock-out feature. Each control will provide a lock-out signal when it is in regeneration. This

lock-out signal will prevent other controls from starting a regeneration when the controls are connected as in Figure 2.

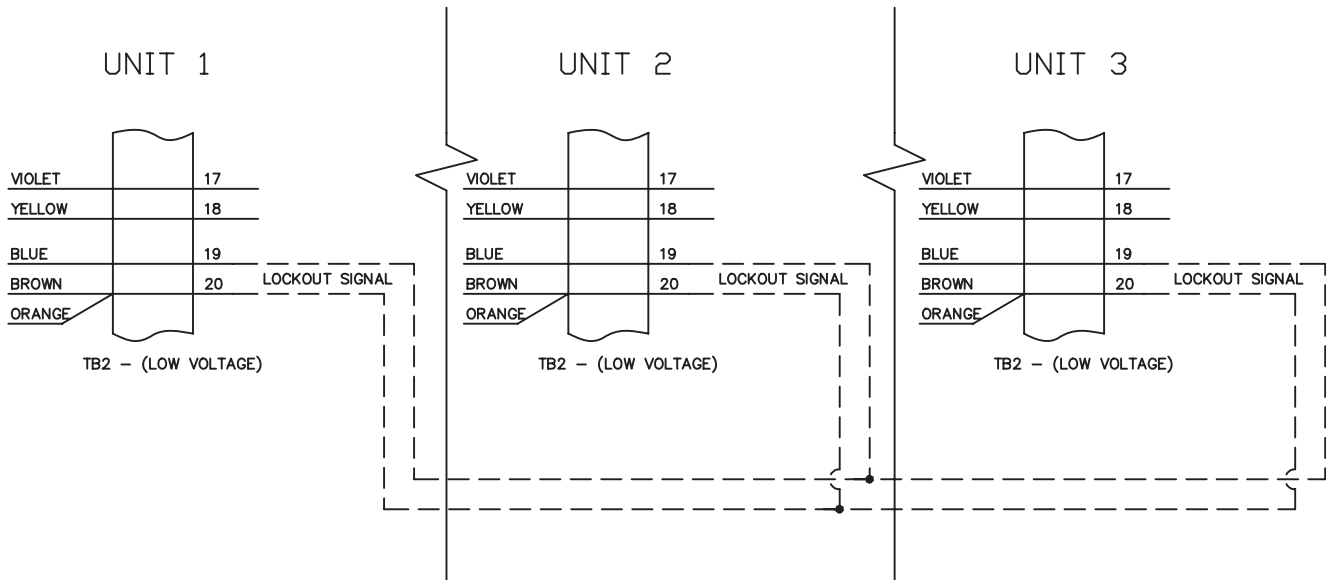

Figure 2 Parallel/Interlock Connections

**NOTE:** The lockout feature is void when using the relay output option.

### Twin Alternating using a model 58-TA stager

The 962 Stager control can be used for Twin Alternating applications by combining a single 962 controller with a single model 58-TA Twin Alternating stager. The alternating of the system is performed by the stager and is independent of the controller. When using a model 58-TA, the “Tank in Service” is indicated by two NEMA 4 rated door-mounted lights that are operated by the stagers second auxiliary switch. **When using a model 58-TA Twin Alternating stager, P17 must be set to a 4 or 6 depending on the number of positions.**

### Twin Alternating using a model 58-TB stager (Timed Brine)

The 962 Stager control can be used for Twin Alternating applications that require a timed brine draw (using 58-TR Stager). These Stagers do not use door-mounted lights to indicate the “Tank in Service”. The controller will display the “Tank in Service” in the left-most digit of the 6-digit display. It will display a 1 or 2 depending on which tank is in service. Flow is also displayed during this time. If any error condition occurs, the “Tank in Service” display will be set to a 2 by default. The controller will reset the display to the proper tank in service once a regeneration is performed on any tank. **When using a model 58-TB or 58-TR Twin Alternating stager, P17 must be set to a 9.**

## Flow Sensor Connections

The 962 Stager control may be connected to a number of different flow sensing devices. Figure 3 shows the connections for the Autotrol turbine type flow sensor. Figure 4 shows the connections for the Signet flow sensor. Most of the flow sensors that are used will be wired similarly, though the wire colors may vary.

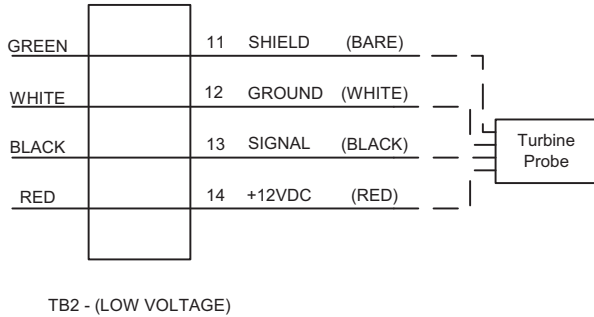

Figure 3 Autotrol Flow Sensor Connections

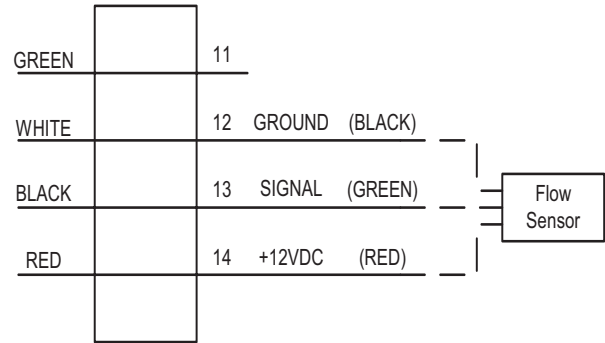

Figure 5 Fleck Flow Sensor Connections

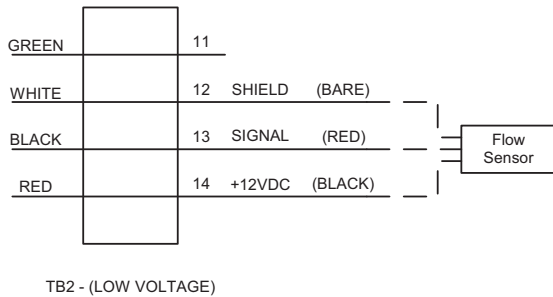

Figure 4 Signet Flow Sensor Connections

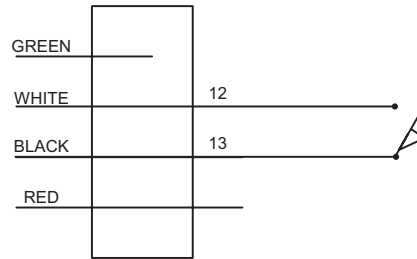

Figure 6 Pulse Transmitter 2 Wire Connection



### AC Power Wiring

The 962 Stager controls have standard voltage configurations of 115 VAC 50/60 Hz, or 230 VAC 50/60 Hz. Power requirements must be specified when ordering. For 115 VAC jumpers are placed between terminals 1 and 3 and 2 and 4. For 230VAC jumpers are placed between terminals 2 and 3 only, Figure 5. Line voltage and neutral inputs are always on terminals 1 and 4 respectively.

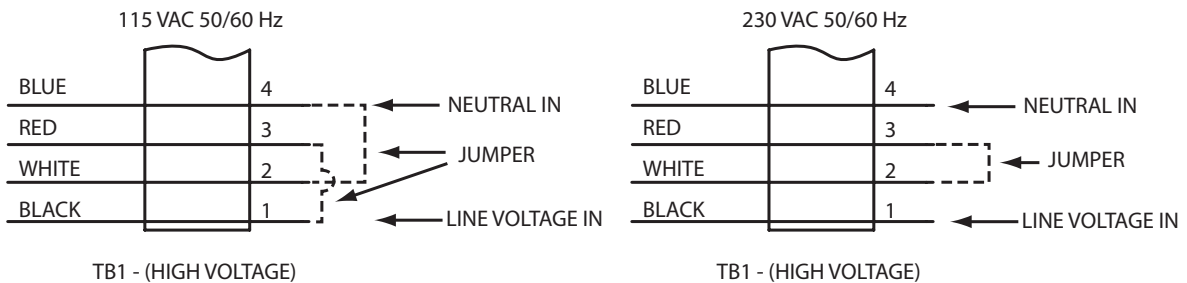

Figure 7 AC Power Connections



## Remote Regeneration

A set of terminals with a programmable delay (P21) are provided as a standard feature of the 962 control, Figure 6. This feature allows for a regeneration to be initiated from a remote location. This feature can also be used to accommodate a differential pressure switch input or any dry contact closure from external equipment. Programmable value "P21" is used to monitor this input for the amount of time that is programmed (in seconds).

P21 is the length of time (in seconds) that the remote input signal will be ignored before starting a regeneration. THE CONNECTION MUST BE A NO VOLTAGE DRY CONTACT.

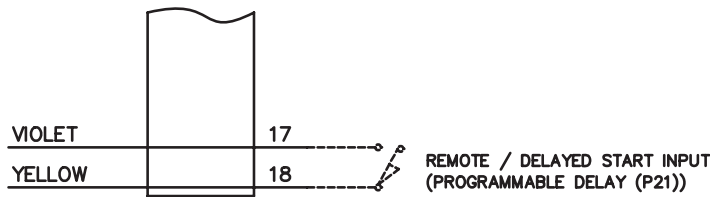

TB2 - (LOW VOLTAGE)

Figure 8 Remote Regeneration Start Connections

## Relay Output Option

A single pole double throw (SPDT) relay may be added for outputs during Regeneration and Service mode. The relay output option is available on single unit and Twin Alternating models only. This feature may not be used however, with the parallel multi-tank systems using the lockout feature. The contacts of this relay are supplied as "Dry Contacts" (un-powered). See Figures 7 and 8 for wiring information.

**NOTE:** The lockout feature is void when using the relay output option.

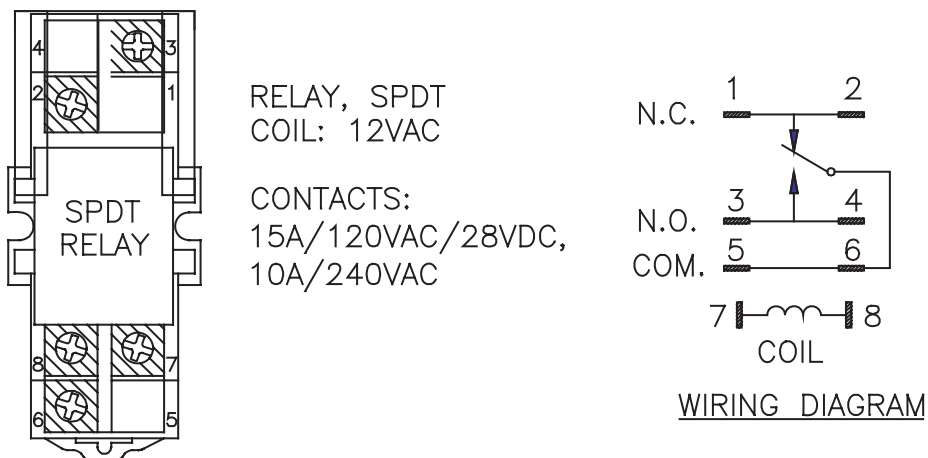

Figure 9 Relay Output Option

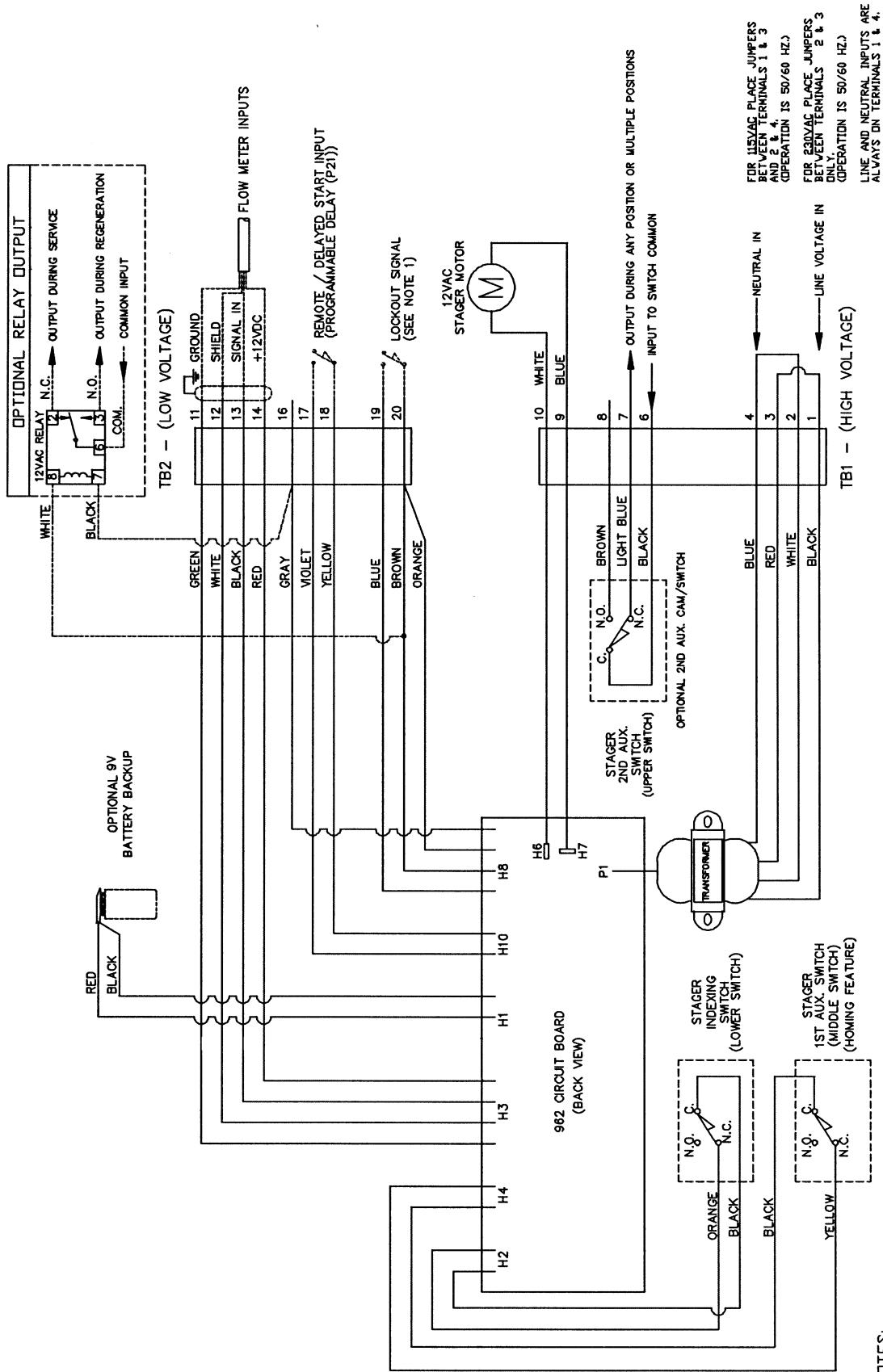

Figure 10 E948/E951 Standard Wiring Design



