

# ULTRAVIOLET SYSTEMS



## UVI SERIES COMMERCIAL / INDUSTRIAL SYSTEMS

Safe Water Technologies' amalgam lamp UV systems are designed for full penetration UV dosing with smaller footprint requirements and reduced operating costs. These full featured 316L stainless steel systems are designed for the most demanding of disinfection applications and engineering designs. All units are available in 254nm or 185nm UV wavelengths.

Whether it is wastewater, potable water, high purity, USP, TOC, or ozone destruct applications, let SWT help you reduce your operating costs and specify the proper equipment for your applications.

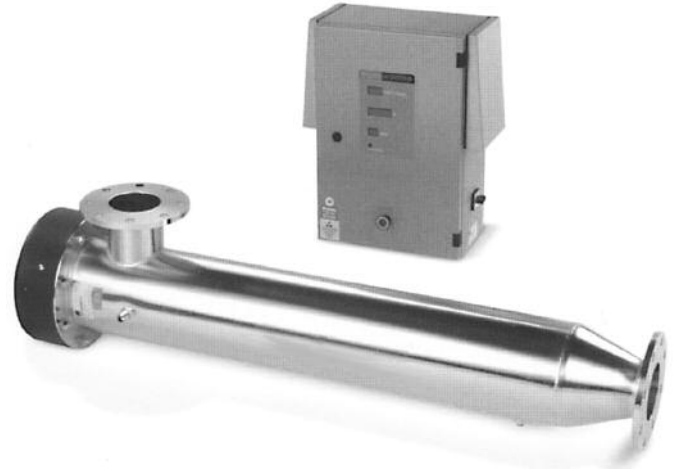

### Standard Features

- 316L stainless steel polished contact chamber
- Flexible vertical or horizontal installation
- Nema 4X stainless steel control panel
- Amalgam low pressure ultraviolet lamp technology
- Digital ultraviolet intensity monitor with alarm
- Remote on/off switch
- Temperature overheat control
- Elapsed time meter
- Available in all international voltages

Part Number	Inlet/Outlet Flange Size Inches	Flow Rate			Shipping Dimensions (L x W x H) Inches	Shipping Weight Lbs. (Kg)
		Clear, Fresh Water	DI & RO Water	Waste Water		
UVI-0040	1.5	40 GPM	50 GPM	25 GPM	44 x 18 x 23	110 (50)
UVI-0065	2	65 GPM	85 GPM	40 GPM	44 x 20 x 30	140 (64)
UVI-0110	2	110 GPM	140 GPM	70 GPM	44 x 20 x 30	150 (68)
UVI-0155	4	155 GPM	200 GPM	100 GPM	44 x 20 x 30	165 (75)
UVI-0230	4	230 GPM	295 GPM	150 GPM	44 x 20 x 30	210 (95)
UVI-0350	4	350 GPM	450 GPM	225 GPM	59 x 30 x 30	275 (125)
UVI-0480	6	480 GPM	610 GPM	310 GPM	59 x 30 x 30	285 (129)
UVI-0560	6	560 GPM	725 GPM	365 GPM	79 x 30 x 30	340 (154)
UVI-0695	6	695 GPM	875 GPM	450 GPM	59 x 30 x 30	335 (152)
UVI-0780	6	780 GPM	975 GPM	505 GPM	79 x 30 x 30	360 (163)
UVI-0875	6	875 GPM	1,060 GPM	555 GPM	59 x 30 x 30	385 (175)
UVI-1120	6	1,120 GPM	1,410 GPM	725 GPM	79 x 30 x 30	390 (177)
UVI-1345	6	1,345 GPM	1,700 GPM	875 GPM	79 x 30 x 30	410 (186)

Optional manual or automatic wiping mechanisms are available. Contact your SWT representative for pricing and details. UV dosages are application dependent. Consult factory.

# ULTRAVIOLET SYSTEMS



## UVI SERIES COMMERCIAL / INDUSTRIAL SYSTEMS

Part Number	Inlet/Outlet Flange Size Inches	Flow Rate			Number of Lamps	Power Watts	Full Load Current Amps	Available Wiping Systems
		Clear, Fresh Water* GPM (m <sup>3</sup> /hr)	DI & RO Water GPM (m <sup>3</sup> /hr)	TOC or Ozone Destruct** GPM (m <sup>3</sup> /hr)				
UVI-0040	1.5	40 (9)	50 (11)	≤ 15 (3)	1	170	3.0	N/A
UVI-0065	2	65 (15)	85 (19)	≤ 26 (6)	1	170	3.0	N/A
UVI-0110	2	110 (25)	140 (32)	≤ 46 (10)	2	280	5.0	Manual Only
UVI-0155	4	155 (35)	200 (45)	≤ 66 (15)	2	280	5.0	Manual Only
UVI-0230	4	230 (52)	295 (67)	≤ 98 (22)	3	400	6.0	Manual Only
UVI-0350	4	350 (79)	450 (102)	≤ 150 (34)	3	625	8.0	Manual/Automatic
UVI-0480	6	480 (109)	610 (139)	≤ 200 (45)	4	780	10.0	Manual/Automatic
UVI-0560	6	560 (127)	725 (165)	≤ 240 (55)	3	930	8.0	Manual/Automatic
UVI-0695	6	695 (158)	875 (199)	≤ 290 (66)	6	1,100	15.0	Manual/Automatic
UVI-0780	6	780 (177)	975 (221)	≤ 325 (74)	4	1,200	10.0	Manual/Automatic
UVI-0875	6	875 (199)	1,060 (241)	≤ 350 (79)	8	1,425	15.0	Manual/Automatic
UVI-1120	6	1,120 (254)	1,410 (320)	≤ 470 (107)	6	1,720	15.0	Manual/Automatic
UVI-1345	6	1,345 (305)	1,700 (386)	≤ 560 (127)	8	2,250	15.0	Manual/Automatic

\* Disinfection Dose Level: 30 mJ/cm<sup>2</sup> @ 95% UVT, after 9,000 hours of operation. Other dosages available upon request.

\*\* TOC or Ozone Destruct Dose Level: Minimum 90 mJ/cm<sup>2</sup> @ 99% UVT, after 9,000 hours of operation. UV dosages are application dependent.

### UVI Series Replacement Parts

Part Number	Description
IL-T1AM	Lamp for UVI-0040, UVI-0065, UVI-0110, UVI-0155, & UVI-0230 Systems
IL-T1AS	Lamp for UVI-0350, UVI-0480, UVI-0695, & UVI-0875 Systems
IL-T1AL	Lamp for UVI-0560, UVI-0780, UVI-1120, & UVI-1345 Systems
IL-T3AM	Quartz Sleeve for UVI-0040, UVI-0065, UVI-0110, UVI-0155, & UVI-0230 Systems
IL-T3AS	Quartz Sleeve for UVI-0350, UVI-0480, UVI-0695, & UVI-0875 Systems
IL-T3AL	Quartz Sleeve for UVI-0560, UVI-0780, UVI-1120, & UVI-1345 Systems
IL-T3ORING	O-ring for all UVI Series Systems

